

DEKLARACJA WŁAŚCIWOŚCI UŻYTKOWYCH

zgodnie z rozporządzeniem w sprawie wyrobów budowlanych (UE) N° 305/2011
N°: LE_09_0021_PL

1. Kod identyfikacyjny typu wyrobu stopy belkowe 2,0
Wymiary: patrz ETA-09/0021
2. Numer typu, partii, serii lub inny
element umożliwiający
identyfikację ETA-09/0021
Numer szarzy: patrz etykieta
3. Zastosowanie Elementy łączące do drewnianych konstrukcji
nośnych, jak również do belek i płatwi zgodnie z
ETA- 09/0021
4. Adres kontaktowy producenta BB Stanz- und Umformtechnik GmbH
Nordhäuser Str. 44
06536 Berga
Germany
5. System lub systemy oceny i
weryfikacji stałości właściwości
użytkowych System 2+
6. Dokument referencyjny ETA-09/0021
7. Jednostka EOTA/numer ETA-Danmark A/S, Charlottenlund
8. Jednostka notyfikowana - przeprowadzi wstępną inspekcję zakładu i
inspekcję zakładowej kontroli produkcji
- przeprowadzi inspekcję stałego nadzoru, oceny
i ewaluacji zakładowej kontroli produkcji
- wystawi certyfikat zgodności 0769-CPD-
6164/01
9. Deklarowane właściwości
użytkowe Patrz ETA-09/0021
10. Właściwości użytkowe wyrobu określonego w punktach 1 i 2 są zgodne z
właściwościami użytkowymi deklarowanymi w punkcie 9. Niniejszą deklarację
właściwości użytkowych wydano na wyłączną odpowiedzialność producenta
określonego w punkcie 4.

W imieniu producenta podpisał:



Günther Blesch
(Kierownik)
Berga, 13.01.2017

LEISTUNGSERKLÄRUNG

im Sinne der Bauprodukte-Verordnung (EU) Nr.305/2011
Nr.: LE_09_0021_DE

- | | | |
|-----|-----------------------------------------------------------------------------------------------------------------------------------------------------------------------------------------------------------|---------------------------------------------------------------------------------------------------------------------------------------------------------------------------------------------------------------------------------------|
| 1. | Kenncode des Produkttyps | BB Balkenschuhe 2,0
Abmessungen: siehe ETA-09/0021 |
| 2. | Typen-, Chargen-,
Seriennummern oder anderes
Kennzeichen zur Identifikation | ETA-09/0021
Chargennummer: siehe Etikett |
| 3. | Verwendungszweck | Verbinder für tragende Holzkonstruktionen, sowie
für die Verbindung von Balken und Pfetten gemäß
ETA-09/0021 |
| 4. | Kontaktanschrift des Herstellers | BB Stanz- und Umformtechnik GmbH
Nordhäuser Str. 44
06536 Berga |
| 5. | System oder Systeme zur
Bewertung und Überprüfung der
Leistungsbeständigkeit | System 2+ |
| 6. | Referenzdokument | ETA-09/0021 |
| 7. | Eota Stelle / Nummer | ETA-DANMARK A/S, Charlottenlund |
| 8. | Durch Zertifizierungsstelle
vorgenommen | - Erstinspektion des Werks und der
werkseigenen Produktionskontrolle
- Laufende Überwachung, Bewertung und
Evaluierung der werkseigenen
Produktionskontrolle
- Ergebnis im Konformitätszertifikat 0769-CPD-
6164/01 |
| 9. | Erklärte Leistung | Siehe ETA-09/0021 |
| 10. | Die Leistung des Produkts gemäß den Nummern 1 und 2 entspricht der erklärten
Leistung nach Nummer 9. Verantwortlich für die Erstellung dieser
Leistungserklärung ist der Hersteller gemäß Nummer 4. | |

Unterzeichnet für den Hersteller und im Namen des Herstellers von:



Günther Blesch
(Geschäftsführer)
Berga, 13.01.2017

ETA-Danmark A/S
Kollegievej 6
DK-2920 Charlottenlund
Tel. +45 72 24 59 00
Fax +45 72 24 59 04
Internet www.etadanmark.dk



Authorised and notified according to
Article 29 of the Regulation (EU)
No 305/2011 of the European
Parliament and of the Council of 9
March 2011

MEMBER OF EOTA

European Technical Assessment ETA-09/0021 of 2014/01/10

I General Part

Technical Assessment Body issuing the ETA and designated according to Article 29 of the Regulation (EU) No 305/2011: ETA-Danmark A/S

Trade name of the construction product:

BB Joist Hangers type A, I and Split 2 mm

Product family to which the above construction product belongs:

EC PAC 13: Three-dimensional nailing plate (Joist hanger for wood to wood connections and wood to concrete or steel connections)

Manufacturer:

BB Stanz- und Umformtechnik GmbH
Nordhäuser Str. 42
D-06536 Berga
Tel. +49 34651 2988 0
Fax +49 34651 2988 20
Internet www.bb-berga.de

Manufacturing plant:

BB Stanz- und Umformtechnik GmbH
Nordhäuser Str. 42
D-06536 Berga

This European Technical Assessment contains:

31 pages including 4 annexes which form an integral part of the document

This European Technical Assessment is issued in accordance with Regulation (EU) No 305/2011, on the basis of:

Guideline for European Technical Approval (ETAG) No. 015 Three Dimensional Nailing Plates, April 2013, used as European Assessment Document (EAD).

This version replaces:

The previous ETA with the same number issued on 2009-01-27 and expiry on 2014-01-27

Translations of this European Technical Assessment in other languages shall fully correspond to the original issued document and should be identified as such.

Communication of this European Technical Assessment, including transmission by electronic means, shall be in full (excepted the confidential Annex(es) referred to above). However, partial reproduction may be made, with the written consent of the issuing Technical Assessment Body. Any partial reproduction has to be identified as such.

II SPECIFIC PART OF THE EUROPEAN TECHNICAL ASSESSMENT

1 Technical description of product and intended use

Technical description of the product

BB joist hangers type A and I are one-piece non-welded, face-fixed joist hangers to be used in timber to timber connections. BB joist hangers type A are also used for connections between a timber joist and a concrete structure or a steel member.

BB joist hangers type split are two-piece non-welded, face-fixed joist hangers to be used in timber to timber connections.

The joist hangers are made from pre-galvanized steel Grade S 250 GD + Z (min Z275) according to EN 10346:2009. Dimensions, hole positions, steel type and typical installations are shown in Annex A.

2 Specification of the intended use in accordance with the applicable EAD

The joist hangers are intended for use in making end-grain to side-grain connections in load bearing timber structures, as a connection between a wood based joist and a solid timber or wood based header, where requirements for mechanical resistance and stability and safety in use in the sense of the Basic Works Requirements 1 and 4 of Regulation (EU) 305/2011 shall be fulfilled. The BB joist hangers type A are also intended for use in making an end-grain connection between a timber joist and a concrete structure or a steel member.

The joist hangers can be installed as connections between wood based members such as:

- Structural solid timber classified to C14-C40 according to EN 338 / EN 14081,
- Glulam classified to GL24-GL36 according to EN 1194 / EN 14080,
- LVL according to EN 14374,
- Parallam PSL,
- Intrallam LSL,
- Duo- and Triobalken,
- Layered wood plates,
- Kreuzbalken,
- I-beams with backer blocks on both sides of the web in the header and web stiffeners in the joist,
- Plywood according to EN 636.

However, the calculation methods are only allowed for a characteristic wood density of up to 460 kg/m^3 . Even though the wood based material may have a larger density, this must not be used in the formulas for the load-carrying capacities of the fasteners.

Annex B states the formulas for the characteristic load-carrying capacities of the connections with joist hangers type A and I and a table with characteristic load-carrying-capacities of connections with joist hangers type split. The design of the connections shall be in accordance with Eurocode 5 or a similar national Timber Code.

It is assumed that the forces acting on the joist hanger connection are the following F_{up} , F_{down} and F_{lat} , as shown in the figure below. The forces F_{up} and F_{down} shall act in the middle of the joist hanger. The force F_{lat} is assumed to act $e_{J,90}$ above the centre of gravity of the nails in the joist. It is assumed that the forces are acting right at the end of the joist.

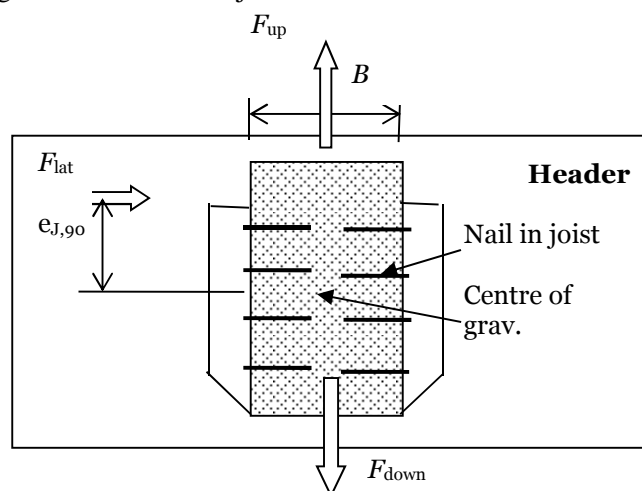

It is assumed that the header beam is prevented from rotating. Similarly it is assumed that the concrete structure or the steel member to which the joist hanger is bolted does not rotate. If the header beam only has installed a joist hanger on one side the eccentricity moment $M_v = F_d \cdot (B_H / 2 + e_{J,0})$ shall be considered. The same applies when the header has joist hanger connections on both sides, but with vertical forces which differ more than 20%.

It is a condition for a force F_{lat} perpendicular to the vertical symmetry line that the joist hanger is connected to a wood-based header with nails in all holes (full nailing) or in all holes marked for partial nailing.

The joist hangers are intended for use for connections subject to static or quasi static loading.

The zinc-coated hangers are for use in timber structures subject to the dry, internal conditions defined by the service classes 1 and 2 of EN 1995-1-1:2004, (Eurocode 5).

The scope of the brackets regarding resistance to corrosion shall be defined according to national provisions that apply at the installation site considering environmental conditions.

The hold downs may also be used for connections between a timber member and a member of concrete or steel.

The provisions made in this European Technical Assessment are based on an assumed intended working life of the hold downs of 50 years.

The indications given on the working life cannot be interpreted as a guarantee given by the producer or Assessment Body, but are to be regarded only as a means for choosing the right products in relation to the expected economically reasonable working life of the works.

3 Performance of the product and references to the methods used for its assessment

Characteristic	Assessment of characteristic
3.1 Mechanical resistance and stability*) (BR1)	
Characteristic load-carrying capacity	See Annex B
Stiffness	No performance determined
Ductility in cyclic testing	No performance determined
3.2 Safety in case of fire (BR2)	
Reaction to fire	The joist hangers are made from steel classified as Euroclass A1 in accordance with EN 1350-1 and EC decision 96/603/EC, amended by EC Decision 2000/605/EC
3.3 Hygiene, health and the environment (BR3)	
Influence on air quality	No dangerous materials
3.4 Safety in use (BR4)	Not relevant
3.5 Protection against noise (BR5)	Not relevant
3.6 Energy economy and heat retention (BR6)	Not relevant
3.7 Sustainable use of natural resources (BR7)	Not relevant
3.8 General aspects related to the performance of the product	The joist hangers have been assessed as having satisfactory durability and serviceability when used in timber structures using the timber species described in Eurocode 5 and subject to the conditions defined by service class 1 and 2
Identification	See Annex A

*) See additional information in section 3.8 – 3.9.

In addition to the specific clauses relating to dangerous substances contained in this European technical Assessment, there may be other requirements applicable to the products falling within its scope (e.g. transposed European legislation and national laws, regulations and administrative provisions). In order to meet the provisions of the Construction Products Regulation, these requirements need also to be complied with, when and where they apply.

3.9 Methods of verification

Safety principles and partial factors

The characteristic load-carrying capacities are based on the characteristic values of the nail connections and the joist hangers. To obtain design values the capacities have to be divided by different partial factors for the material properties, the nail connection in addition multiplied with the coefficient k_{mod} .

According to EN 1990 (Eurocode – Basis of design) paragraph 6.3.5 the design value of load-carrying capacity may be determined by reducing the characteristic values of the load-carrying capacity with different partial factors.

Thus, the characteristic values of the load-carrying capacity are determined also for timber failure $F_{Rk,H}$ (obtaining the embedment strength of nails subjected to shear or the withdrawal capacity of the most loaded nail, respectively) as well as for steel plate failure $F_{Rk,S}$. The design value of the load-carrying capacity is the smaller value of both load-carrying capacities.

$$F_{Rd} = \min \left\{ \frac{k_{mod} \cdot F_{Rk,H}}{\gamma_{M,H}}, \frac{F_{Rk,S}}{\gamma_{M,S}} \right\}$$

Therefore, for timber failure the load duration class and the service class are included. The different partial factors γ_M for steel or timber, respectively, are also correctly taken into account.

3.10 Mechanical resistance and stability

See annex B for characteristic load-carrying capacities of the joist hangers.

The characteristic capacities of the joist hangers are determined by calculation assisted by testing as described in the EOTA Guideline 015 clause 5.1.2. They should be used for designs in accordance with Eurocode 5 or a similar national Timber Code.

The design models allow the use of fasteners described in the table on page 13 in Annex A:

Threaded nails (ringed shank nails) in accordance to EN 14592

In the formulas in Annex B the capacities for threaded nails calculated from the formulas of Eurocode 5 are used assuming a thick steel plate when calculating the lateral nail load-carrying-capacity.

Further, the joist hangers may be fastened to a concrete structure or steel member by bolts with a diameter of 10 mm in holes with a diameter up to 2 mm larger than the bolt.

The load bearing capacities of the brackets has been determined based on the use of connector nails 4,0 x L mm in accordance with the German national approval for the nails.

The characteristic withdrawal capacity of the nails has to be determined by calculation in accordance with EN 1995-1-1: 2004, paragraph 8.3.2 (head pull-through is not relevant):

$$F_{ax,Rk} = f_{ax,k} \times d \times t_{pen}$$

Where:

$f_{ax,k}$	Characteristic value of the withdrawal parameter in N/mm^2
d	Nail diameter in mm
t_{pen}	Penetration depth of the profiles shank in mm

Based on tests by Versuchsanstalt für Stahl, Holz und Steine, University of Karlsruhe, the characteristic value of the withdrawal resistance for the threaded nails used can be calculated as:

$$f_{ax,k} = 50 \times 10^{-6} \times \sigma_k^2$$

Where:

σ_k	Characteristic density of the timber in kg/m^3
------------	--------------------------------------------------

The shape of the nail directly under the head shall be in the form of a truncated cone with a diameter under the nail head which exceeds the hole diameter.

4,0 mm threaded nails with a truncated cone below the head are used as fasteners, which are particularly suitable for nailed steel-to-timber connections. The specific shape below the head causes a clamping of nails in the steel plate.

No performance has been determined in relation to ductility of a joint under cyclic testing. The contribution to the performance of structures in seismic zones, therefore, has not been assessed.

No performance has been determined in relation to the joint's stiffness properties - to be used for the analysis of the serviceability limit state.

3.11 Aspects related to the performance of the product

3.11.1 Corrosion protection in service class 1 and 2.

The joist hangers have a zinc coating weight of min Z275. The steel employed is S250 GD with min Z275 according to EN 10346:2009.

3.12 General aspects related to the fitness for use of the product

The hold downs are manufactured in accordance with the provisions of this European Technical Assessment using the manufacturing processes as identified in the inspection of the plant by the notified inspection body and laid down in the technical documentation

The nailing pattern used shall be either the maximum or the minimum pattern as defined in Annex A.

The following provisions concerning product performance apply:

Joist hanger connections

A joist hanger connection is deemed fit for its intended use provided:

Header – support conditions

- The header beam shall be restrained against rotation and be free from wane under the joist hanger.

If the header carries joists only on one side the eccentricity moment from the joists $M_{ec} = R_{joist} (b_{header}/2 + e_{1,0})$ shall be considered at the strength verification of the header.

R_{joist}	Reaction force from the joists
b_{header}	Width of header
$e_{1,0}$	Distance from the centroid of the nails in the joist to the surface of the header

- For a header with joists from both sides but with different reaction forces a similar consideration applies.

Wood to wood connections

- Joist hangers are fastened to wood-based members by nails.
- There shall be nails in all holes or a partial nailing pattern as prescribed in Annex A-D may be used.
- The characteristic capacity of the joist hanger connection is calculated according to the manufacturer's technical documentation, dated 2008-11-22.
- The joist hanger connection is designed in accordance with Eurocode 5 or an appropriate national code.
- The gap between the end of the joist and the surface, where contact stresses can occur during loading shall be limited. This means that for joist hangers with outward flaps the gap between the

surface of the end of the joist and that of the header shall be maximum 3 mm.

Joist hangers with inward flaps the gap between the surface of the nail heads in the inward flaps and the end of the joist shall be maximum 8 mm.

- For joist hangers A, I and split the width of the joist shall be at least $l + 4d$, where l is the length of the fasteners and d is the fastener diameter in the joist, for full nailing and partial nailing without staggering the fasteners in the joist. For nailing with staggered fasteners in the joist the width shall be at least the penetration length of the fasteners.
- The cross section of the joist at the joist hanger connection shall have sharp edges at the lower side against the bottom plate, i.e. it shall be without wane.
- The cross section of the header shall have a plane surface against the whole joist hanger.
- The width B_j of the joist shall correspond to that of the joist hanger. B_j shall not be smaller than $B - 3$ mm, where B is the inner width of the joist hanger.
- The depth of the joist shall be so large that the top of the joist is at least 20 mm above the upper fastener in the joist.
- Nails to be used shall have a diameter, which fits the holes of the joist hangers.

Wood to concrete or steel

The above mentioned rules for wood to wood connections are applicable also for the connection between the joist and the joist hanger.

- The joist hanger shall be in close contact with the concrete or steel over the whole face. There shall be no intermediate layers in between.
- The gap between the end of the joist and the surface, where contact stresses can occur during loading shall be limited. This means that the gap between the surface of the end of the joist and that of the concrete or steel shall be maximum 3 mm.
- The bolt shall have a diameter not less than the hole diameter minus 2 mm.
- The bolts shall be placed symmetrically about the vertical symmetry line. There shall always be bolts in the 2 upper holes.
- The upper bolts shall have washers according to EN ISO 7094.

4 Attestation and verification of constancy of performance (AVCP)

4.1 AVCP system

According to the decision 97/638/EC of the European Commission¹, as amended, the system(s) of assessment and verification of constancy of performance (see Annex V to Regulation (EU) No 305/2011) is 2+.

- a) Tasks for the manufacturer:
Factory production control,
 - (1) Initial type testing of the product,
- b) Tasks for the notified body:
 - (1) Initial inspection of the factory and the factory production control,
 - (2) Continuous surveillance

5 Technical details necessary for the implementation of the AVCP system, as foreseen in the applicable EAD

5.1 Tasks of the manufacturer

5.1.1 Factory production control

The manufacturer has a factory production control system in the plant and exercises permanent internal control of production. All the elements, requirements and provisions adopted by the manufacturer are documented in a systematic manner in the form of written policies and procedures. This production control system ensures that the product is in conformity with the European Technical Assessment.

The manufacturer shall only use raw materials supplied with the relevant inspection documents as laid down in the control plan¹. The incoming raw materials shall be subject to controls and tests by the manufacturer before acceptance. Check of materials, such as sheet metal, shall include control of the inspection documents presented by suppliers (comparison with nominal values) by verifying dimension and determining material properties, e.g. chemical composition, mechanical properties.

The manufactured components are checked visually and for dimensions.

The control plan, which is part of the technical documentation of this European Technical Assessment, includes details of the extent, nature and frequency of testing and controls to be performed within the factory

¹ The control plan has been deposited at ETA-Danmark and is only made available to the approved bodies involved in the AVCP procedure.

production control and has been agreed between the Assessment holder and ETA-Danmark.

The results of factory production control are recorded and evaluated. The records include at least the following information:

- Designation of the product, basic material and components;
- Type of control or testing;
- Date of manufacture of the product and date of testing of the product or basic material and components;
- Result of control and testing and, if appropriate, comparison with requirements;
- Signature of person responsible for factory production control.

The records shall be presented to ETA Danmark on request.

5.1.2 Initial type testing of the product

For initial type-testing the results of the tests performed as part of the assessment for the European Technical Assessment shall be used unless there are changes in the production line or plant. In such cases the necessary initial type testing has to be agreed between ETA-Danmark and the notified body.

5.2. Tasks of notified bodies

5.2.1 Initial inspection of factory and of factory production control

The Notified body shall ascertain that, in accordance with the control plan, the factory and the factory production control are suitable to ensure continuous and orderly manufacturing of the anchor according to the specifications mentioned in 2.1 as well as to the Annexes to the European Technical Assessment.

5.2.2 Continuous surveillance

The Notified body shall visit the factory at least once a year for regular inspection. It has to be verified that the system of factory production control and the specified automated manufacturing process are maintained taking account of the control plan.

Continuous surveillance and assessment of factory production control have to be performed according to the control plan.

The results of product certification and continuous surveillance shall be made available on demand by the certification body or inspection body, respectively, to ETA-Danmark. In cases where the provisions of the European Technical Assessment and the control plan are no longer fulfilled the conformity certificate shall be withdrawn.

Issued in Charlottenlund on 2014-01-10 by



Thomas Bruun
Manager, ETA-Danmark

Annex A
Product details and definitions

Joist hanger type A

Face mount hanger with external flanges. 2.0 mm thick pre-galvanized steel S250GD + Z (min Z275) according to EN 10326:2004 with tolerances according to EN 10143:1993.

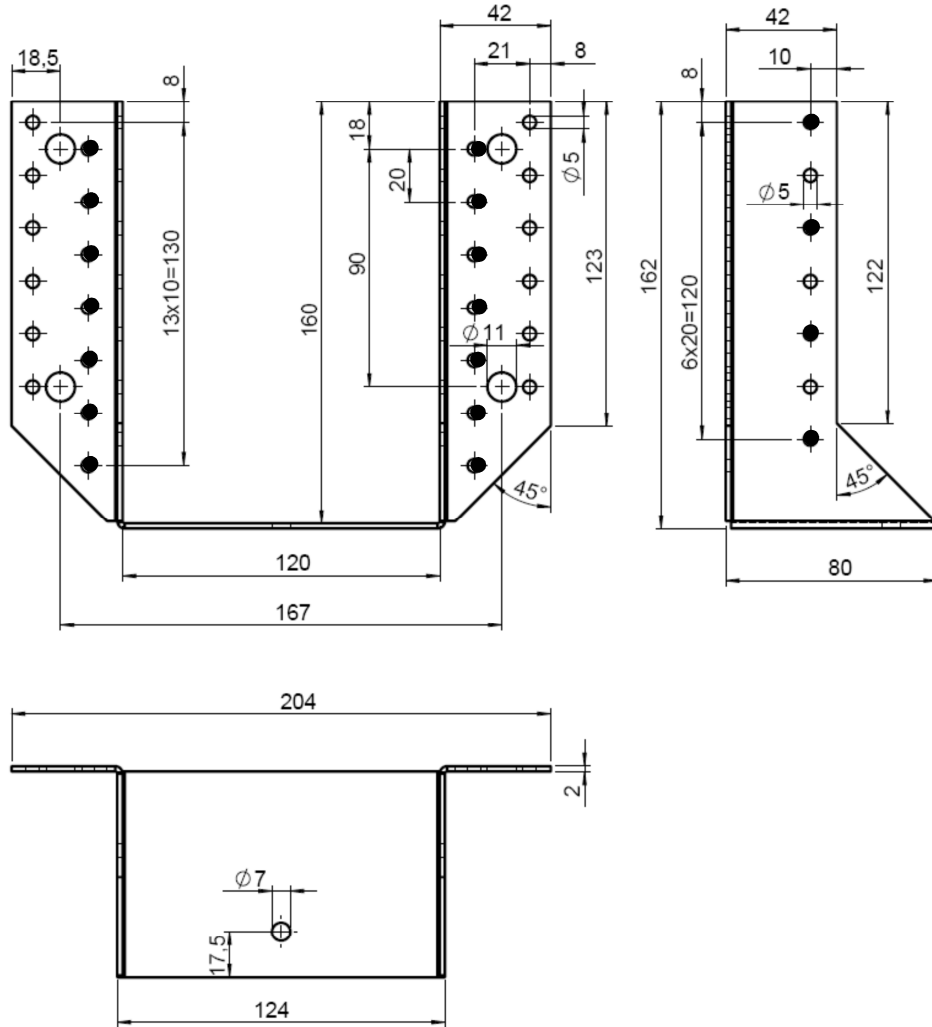

- Partial nailing; Drawing: Blank 440, 2,0 mm steel

Blank	Total n° of nail holes		Width interval		Height interval		Bolt holes		A
	n _H	n _L	min	max	min	max	n°	Diameter	
200	8	6	25	64	68	87,5	2	11	= B + 84
210	10	6	25	50	80	92,5	2	11	= B + 84
220	10	6	25	60	80	97,5	2	11	= B + 84
240	10	6	32	80	80	104	2	11	= B + 84
250	14	8	32	50	100	109	4	11	= B + 84
260	14	8	40	60	100	110	4	11	= B + 84
280	14	8	40	80	100	110	2	11	= B + 84
300	14	8	45	100	100	127,5	4	11	= B + 84
320	16	10	50	100	110	135	4	11	= B + 84
340	18	10	50	100	120	145	4	11	= B + 84
360	22	12	60	80	140	150	4	11	= B + 84
380	24	12	60	76	152	160	4	11	= B + 84
400	22	12	60	120	140	170	4	11	= B + 84
420	26	14	80	100	160	170	4	11	= B + 84
440	26	14	80	120	160	180	4	11	= B + 84
480	30	16	80	120	180	200	6	11	= B + 84
500	30	16	80	140	180	210	6	11	= B + 84

Joist hanger's height = (blank – width)/2

Joist hanger type I

Face mount hanger with interior flanges. 2.0 mm thick pre-galvanized steel S250GD + Z (min Z275) according to EN 10326:2004 with tolerances according to EN 10143:1993.

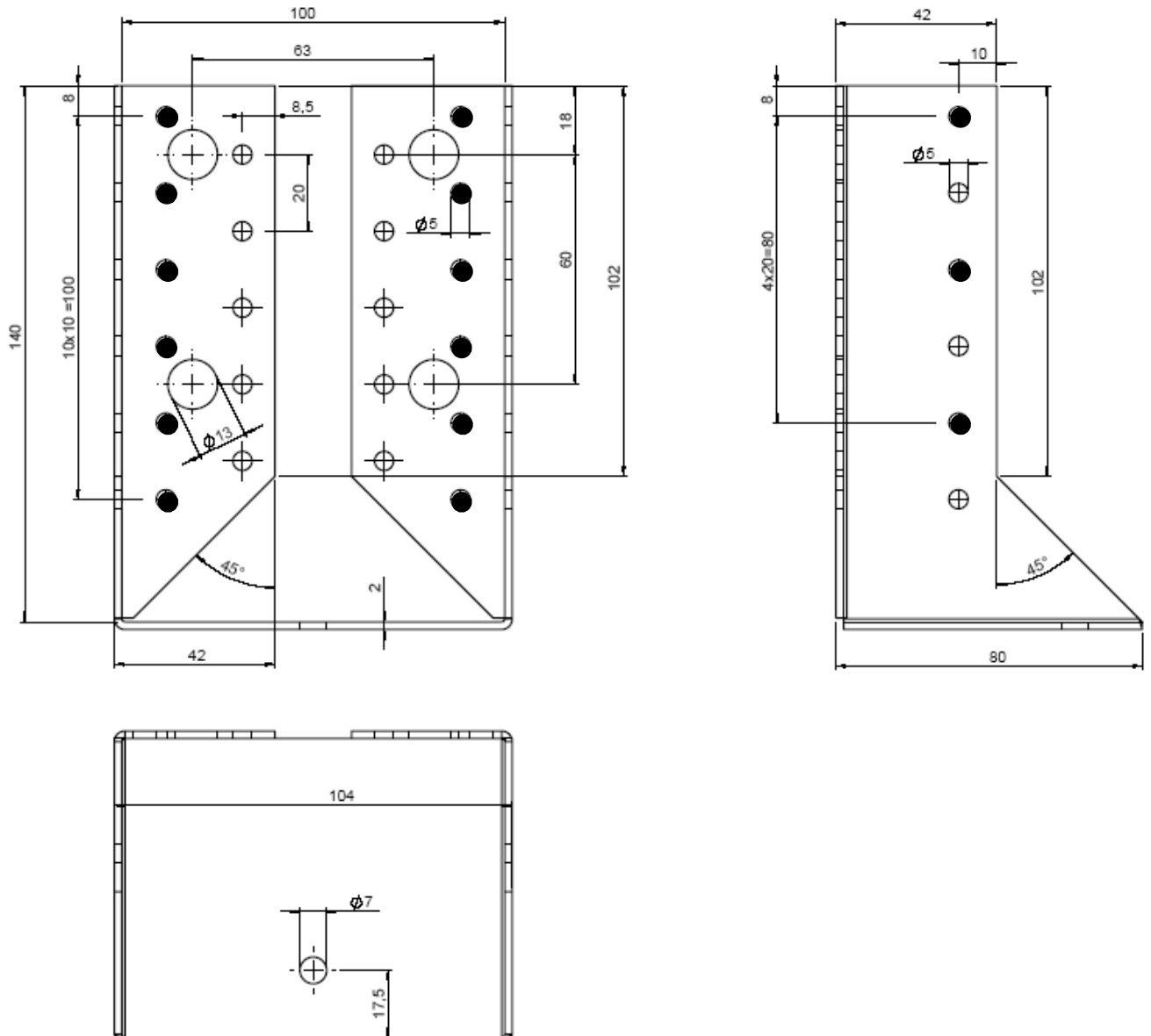

- Partial nailing; Drawing: Blank 380, 2,0 mm steel

Blank	Total n° of nail holes		Width interval		Height interval	
	n _H	n _I	min	max	min	max
250	8	8	46	50	102	105
260	8	8	46	60	100	107
280	16	8	80	80	100	100
300	14	8	80	100	100	110
320	10	10	60	78	121	130
320	18	10	80	90	115	120
380	14	12	60	78	151	160
380	22	12	80	100	140	150
440	14	16	60	78	181	190
440	26	16	80	120	160	180
480	16	18	60	78	201	210
480	30	18	80	120	180	200
500	16	18	60	78	211	220
500	30	18	80	140	180	210

Joist hanger's height = (blank – width)/2

Joist hanger type split

Face mount hanger with external flanges. 2.0 mm thick pre-galvanized steel S250GD + Z (min Z275) according to EN 10326:2004 with tolerances according to EN 10143:1993.

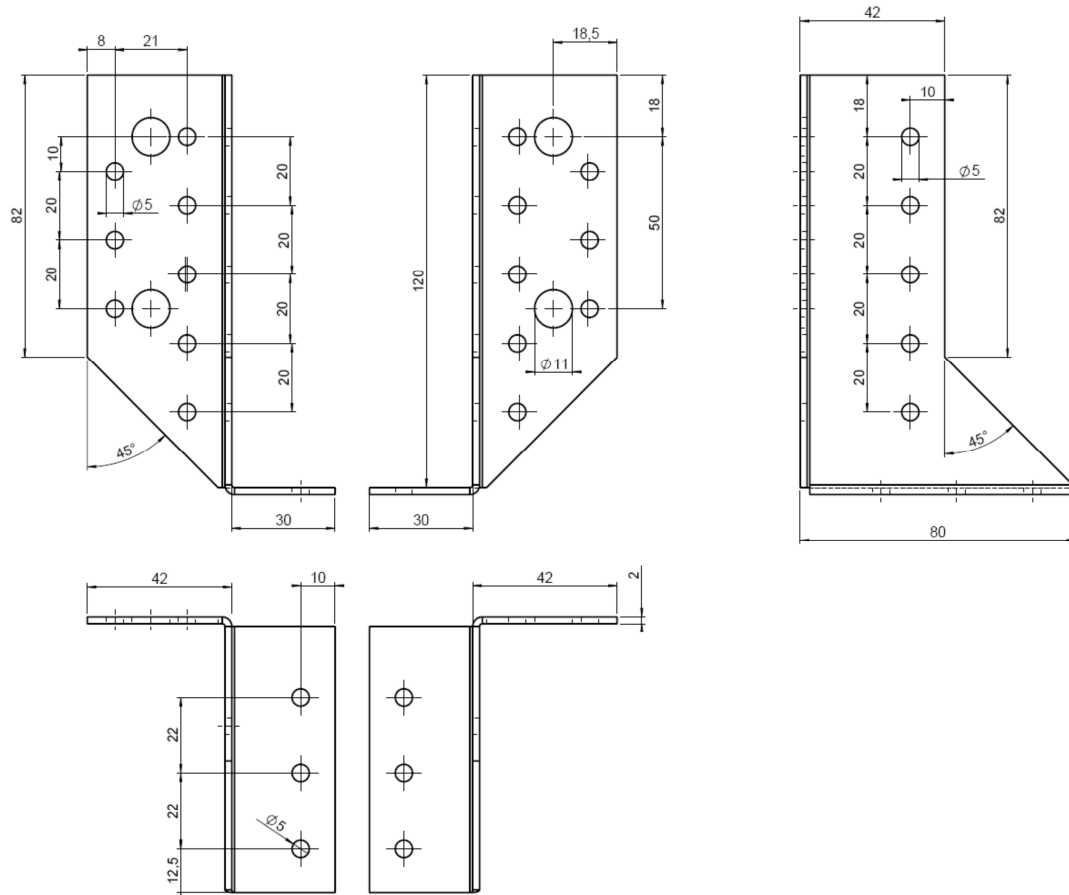

Drawing: Size 30 x 120, 2,0 mm steel

Size	Total n° of nail holes	
	n _H	n _J
30 x 80	10	6
30 x 100	14	8
30 x 120	16	10
30 x 140	22	12
30 x 160	24	12

Fastener types and sizes

NAIL diameter	Length Min – max	Nail type
4.0	40 - 100	Ringed shank nails according to prEN 14592
<p>In the formulas in Annex B the capacities for threaded nails calculated from the formulas of Eurocode 5 are used assuming a thick steel plate when calculating the lateral nail load-carrying-capacity. The load bearing capacities of the joist hangers has been determined based on the use of connector nails 4,0 x L mm in accordance with the German national approval for the nails. The characteristic withdrawal capacity of the nails has to be determined by calculation in accordance with EN 1995-1-1: 2004, paragraph 8.3.2 (head pull-through is not relevant):</p> $F_{ax,Rk} = f_{1,k} \times d \times t_{pen}$ <p>Where:</p> <p>$f_{1,k}$ Characteristic value of the withdrawal parameter in N/mm² d Nail diameter in mm t_{pen} Penetration depth of the profiled shank in mm</p> <p>Based on tests by Versuchsanstalt für Stahl, Holz und Steine, University of Karlsruhe, the characteristic value of the withdrawal resistance for the threaded nails used can be calculated as:</p> $f_{1,k} = 50 \times 10^{-6} \times \rho_k^2$ <p>Where:</p> <p>ρ_k Characteristic density of the timber in kg/m³</p> <p>The shape of the nail directly under the head shall be in the form of a truncated cone with a diameter under the nail head which exceeds the hole diameter.</p>		

BOLTS diameter	Correspondence Hole diameter	Bolts type
10.0	Max. 2 mm. larger than the bolt diameter	See specification of the manufacturer

Annex B

Characteristic values of load-carrying-capacities

Characteristic capacities of the joist hanger connections with nails only

The downward and the upward directed forces are assumed to act in the middle of the joist. The lateral force is assumed to act at an distance $e_{J,90}$ above the centre of gravity of the nails in the joist.

Two nails patterns are specified. A full nailing pattern, where there are nails in all the holes and a partial nailing pattern, where the number of nails in the joist and the header are at least half the numbers specified for full nailing. The nails in the joist may be staggered. The nails in the header shall be put in the holes closest to the bend line.

For BB joist hangers the width of the joist shall be at least $l+4d$, where l is the length of the nails and d is the diameter of the nails in the joist, for full nailing and partial nailing without staggering the nails in the joist. For partial nailing with staggered nails in the joist the width shall be at least the penetration length of the nails.

B.1 Joist hangers types A and I fastened with nails

Force downward toward the bottom plate:

$$F_{Z,Rd} = \min \left\{ \frac{(n_J + 2) \cdot F_{v,J,Rd}}{\sqrt{\left(\frac{1}{n_H \cdot F_{v,H,Rd}}\right)^2 + \left(\frac{1}{k_{H,1} \cdot F_{ax,H,Rd}}\right)^2}} \right. \quad (B.1.1.1)$$

Force upward away from the bottom plate:

$$F_{Z,Rd} = \min \left\{ \frac{n_J \cdot F_{v,J,Rd}}{\sqrt{\left(\frac{1}{n_H \cdot F_{v,H,Rd}}\right)^2 + \left(\frac{1}{k_{H,2} \cdot F_{ax,H,Rd}}\right)^2}} \right. \quad (B.1.1.2)$$

Lateral force:

$$F_{Y,Rd} = \min \left\{ \frac{n_J \cdot F_{v,J,Rd}}{\sqrt{\left(\frac{2 \cdot \sqrt{e_{J,0}^2 + e_{J,90}^2}}{b_J}\right)^2 + \left(\frac{F_{v,J,Rd}}{F_{ax,J,Rd}}\right)^2}} \right. \quad (B.1.1.3)$$

$$\left. \frac{F_{v,H,Rd}}{\sqrt{\left(\frac{1}{n_H} + \frac{e_H}{e_1}\right)^2 + \left(\frac{e_H}{e_2}\right)^2}} \right\}$$

n_J total number of nails in both sides of the joist

n_H total number of nails in the side of the header

$F_{v,Rd}$ Characteristic lateral load-carrying capacity of the fasteners in the joist or in the header indicated by the indices J or H

$F_{ax,Rd}$ Characteristic axial load-carrying capacity of the fasteners in the joist or in the header indicated by the indices J or H

b_J width of the joist hanger, see figure B1.

$e_{J,90}$ distance of the lateral force above the centre of gravity of the nails in the joist, see figure B1.

$e_{J,0}$ distance from the nails in the joist to the surface of the header, see figure B1.

e_H distance of the lateral force above the centre of gravity of the nails in the header.

e_1 joist hanger dimension, see Annex C

e_2 joist hanger dimension, see Annex C

$k_{H,1}$ form factor, see Annex C

$k_{H,2}$ form factor, see Annex C

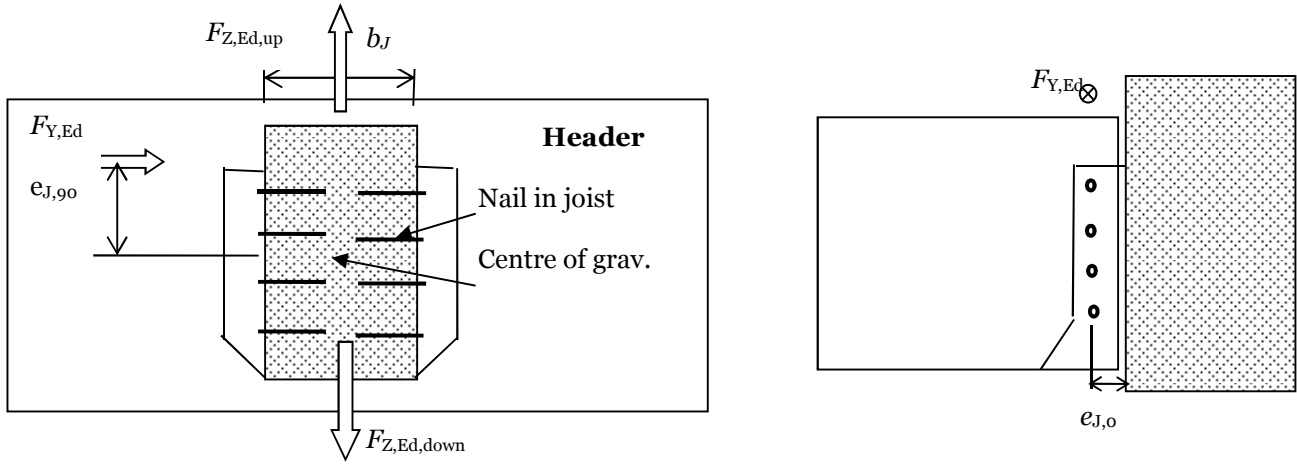

Figure B1: Definition of $e_{J,90}$ and $e_{J,0}$

B.1.2 Combined forces

In case of combined forces shall the following inequality be fulfilled:

$$\left(\frac{F_{Y,Ed}}{F_{Y,Rd}} \right)^2 + \left(\frac{F_{Z,Ed}}{F_{Z,Rd}} \right)^2 \leq 1 \quad (\text{B.1.2.1})$$

B.2 Joist hangers type split fastened with nails

Type	Force downward towards or upward away from the bottom plate $F_{Z,Rk}$ [kN]	Lateral Force $F_{Y,Rk}$ [kN]	
	Timber	Timber	Steel
30 x 80	5,01	9,70	4,09
30 x 100	8,11	13,6	5,13
30 x 120	10,8	15,5	6,14
30 x 140	15,3	20,8	7,18
30 x 150	17,0	21,8	7,30
30 x 160	18,9	22,9	7,42

For timber or wood based material with a lower characteristic density than 350 kg/m^3 the load-carrying capacities shall be reduced by the k_{dens} factor:

$$k_{\text{dens}} = \left(\frac{\rho_k}{350} \right)^2 \quad \text{where } \rho_k \text{ is the characteristic density of the timber in } \text{kg/m}^3.$$

B.2.2 Combined forces

If the forces $F_{Y,Ed}$ and $F_{Z,Ed}$ act at the same time or if $e_H \neq 0$, the following inequality shall be fulfilled:

$$\left(\frac{F_{Y,Ed}}{F_{Y,Rd}} \right)^2 + \left(\frac{F_{Z,Ed} + 2 \cdot \Delta F_{Z,Ed}}{F_{Z,Rd}} \right)^2 \leq 1 \quad (\text{B.2.1})$$

Where:

$$\Delta F_{Z,Ed} = F_{Y,Ed} \cdot \frac{e_H}{B} \quad (\text{B.2.2})$$

B.3 Characteristic capacities of the joist hanger type A connections with bolts

For joist hangers type A connected to a wall of concrete, lightweight concrete or to a steel member the assumptions for the calculation of the load-carrying capacity of the connection are:

- The transfer of force from the joist to the joist hanger is as for a wood-wood connection, see clause B.1;
- The bolts shall always be positioned symmetrically about the vertical axis of the joist hanger;
- Washers according to EN ISO 7094 shall be installed at least under the upper 2 bolt heads or nuts.

Description of the static model

For a downward directed force toward the bottom plate the static behavior is basically the same as for a wood-wood connection with nails.

The nails in the joist are subjected to a lateral force, which is equally distributed over all nails in the joist.

Since the concrete and steel have a larger compressive strength than timber subjected perpendicular to the grain the rotation point may be assumed positioned at the top of the bottom plate.

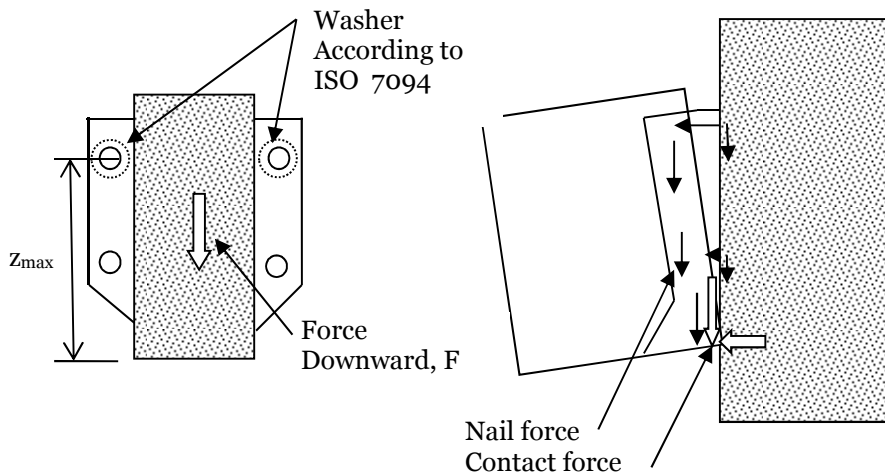

Figure B2 Left: Cross section in joist. Right: The joist will deflect and rotate, at the bottom a contact force will occur at the bottom plate, and the withdrawal forces in the bolts in the wall will vary linearly as assumed for nailed connections in the header.

The forces in the bolts will be partly lateral forces, partly withdrawal forces. The lateral forces are distributed evenly over all bolts. The withdrawal forces are on the safe side assumed to be taken by the 2 upper bolts with washers. The maximum withdrawal force in a upper bolt can be calculated from

$$F_{\text{ax,bolt}} = \frac{F \cdot e_{J,0}}{2 \cdot z_{\text{max}}} \quad (\text{B.3.1})$$

Where

F downward directed force toward the bottom plate;

$e_{J,0}$ eccentricity = distance from the nail column in the joist to the surface of the header;

z_{max} max distance from upper bolt to the bottom plate (rotation point).

The upper 2 bolts are critical. They are subjected to a lateral force and a withdrawal force. The lateral force is determined assuming an even distribution of the downward force F.

$$F_{\text{lat,bolt}} = F/n_{\text{bolt}} \quad (\text{B.3.2})$$

Characteristic capacities of a bolted joist hanger connection

The Characteristic capacity of the connection between the joist and the joist hanger may be calculated from the same assumptions and formulas as for joist hangers nailed to a wooden header beam.

$$F_{Z,Rk} = (n_J + 2) \cdot F_{v,J,Rk} \quad \text{for threaded nails} \quad (\text{B.3.3})$$

The upper 2 bolts are critical. They are subjected to a lateral force calculated from formula (B.3.2).

The withdrawal force in an upper bolt is calculated from (B.3.1).

Where

F downward directed force toward the bottom plate

n_{bolt} total number of bolts in the joist hanger

$e_{J,0}$ eccentricity = distance from the nail column in the joist to the surface of the header

z_{max} max distance from the upper bolt to the bottom plate (rotation point)

It shall be verified by the design of the bolted connection that the upper bolts have sufficient load-carrying capacity to carry the combined lateral and axial forces.

From the Characteristic load-carrying-capacity of the bearing resistance between the bolt and the plate of the joist hanger the following maximum characteristic capacity of the joist hanger connection can be determined.

$$F_{\text{bear,Rk}} = n_{\text{bolt}} \cdot f_{u,k} \cdot d \cdot t \quad (\text{B.3.4})$$

where

n_{bolt} total number of bolts in the 2 flaps

$f_{u,k}$ characteristic ultimate tensile strength of the steel

d diameter of the bolt

t thickness of the steel plate of the joist hanger

The characteristic load-carrying capacity of the joist hanger connections is the minimum of:

- The capacity determined from (B.3.3) from the fasteners in the joist;
- The capacity determined from (B.3.4) from the embedding strength of the steel plate against the bolt;
- The capacity controlled by the bolt forces given by (B.3.1) and (B.3.2).

Annex C
Form factors $k_{H,1}$ and $k_{H,2}$ and dimensions e_1 , e_2 and $e_{J,0}$

Table C1: Joist hanger type A with external flanges:
Form factors $k_{H,1}$ and $k_{H,2}$ and dimensions e_1 , e_2 ; $e_{J,0} = 32$ mm

B [mm]	H [mm]	n_H	n_J	$k_{H,1}$	$k_{H,2}$	e_1 [mm]	e_2 [mm]	n_H	n_J	$k_{H,1}$	$k_{H,2}$	e_1 [mm]	e_2 [mm]
Full nailing								Partial nailing					
25	87,5	8	6	12,3	1,17	835	272	4	4	5,75	0,81	240	126
32	84	8	6	11,5	1,23	975	296	4	4	5,35	0,85	292	137
36	82	8	6	11,0	1,27	1062	309	4	4	5,13	0,88	325	143
38	81	8	6	10,8	1,29	1107	316	4	4	5,02	0,89	342	146
40	80	8	6	10,6	1,31	1153	323	4	4	4,91	0,91	359	150
45	77,5	8	6	10,0	1,37	1272	341	4	4	4,63	0,95	406	158
50	75	8	4	9,43	1,43	1398	358	4	4	4,36	0,99	455	167
52	74	8	4	9,20	1,45	1450	366	4	4	4,25	1,00	476	170
54	73	8	4	8,98	1,48	1503	373	4	4	4,15	1,02	497	174
56	72	8	4	8,75	1,50	1558	380	4	4	4,04	1,04	519	177
58	71	8	4	8,53	1,53	1613	387	4	4	3,94	1,06	542	181
60	70	8	4	8,31	1,56	1670	394	4	4	3,83	1,08	565	184
62	69	8	4	8,09	1,59	1727	402	4	4	3,73	1,10	588	198
64	68	8	4	7,88	1,63	1786	409	4	4	3,63	1,13	612	202
25	92,5	10	6	13,3	2,52	726	316	6	4	8,15	1,68	283	218
32	89	10	6	12,3	2,64	851	344	6	4	7,57	1,76	341	231
36	87	10	6	11,8	2,72	928	360	6	4	7,25	1,81	378	240
38	86	10	6	11,5	2,76	968	369	6	4	7,09	1,84	397	244
40	85	10	6	11,2	2,80	1009	377	6	4	6,93	1,87	417	249
45	82,5	10	6	10,6	2,91	1116	399	6	4	6,53	1,94	469	260
50	80	10	6	9,90	3,02	1229	420	6	4	6,14	2,02	525	273
25	97,5	10	6	14,7	2,36	726	316	6	4	8,98	1,57	283	218
32	94	10	6	13,7	2,47	851	344	6	4	8,39	1,64	341	231
36	92	10	6	13,2	2,53	928	360	6	4	8,06	1,69	378	240
38	91	10	6	12,9	2,57	968	369	6	4	7,90	1,71	397	244
40	90	10	6	12,6	2,60	1009	377	6	4	7,74	1,74	417	249
45	87,5	10	6	11,9	2,70	1116	399	6	4	7,33	1,80	469	260
50	85	10	6	11,2	2,80	1229	420	6	4	6,93	1,87	525	273
52	84	10	6	11,0	2,84	1276	429	6	4	6,77	1,89	548	278
54	83	10	6	10,7	2,88	1324	438	6	4	6,61	1,92	572	283
56	82	10	6	10,4	2,93	1373	447	6	4	6,45	1,95	597	288
58	81	10	6	10,2	2,98	1423	455	6	4	6,30	1,98	622	293
60	80	10	6	9,90	3,02	1474	464	6	4	6,14	2,02	648	298
32	104	10	6	16,6	2,18	851	344	6	4	10,1	1,45	341	231
36	102	10	6	16,0	2,23	928	360	6	4	9,74	1,49	378	240
38	101	10	6	15,7	2,26	968	369	6	4	9,57	1,51	397	244
40	100	10	6	15,4	2,29	1009	377	6	4	9,40	1,52	417	249
45	97,5	10	6	14,7	2,36	1116	399	6	4	8,98	1,57	469	260
50	95	10	6	14,0	2,44	1229	420	6	4	8,56	1,62	525	273
52	94	10	6	13,7	2,47	1276	429	6	4	8,39	1,64	548	278
54	93	10	6	13,4	2,50	1324	438	6	4	8,23	1,67	572	283
56	92	10	6	13,2	2,53	1373	447	6	4	8,06	1,69	597	288
58	91	10	6	12,9	2,57	1423	455	6	4	7,90	1,71	622	293

Table C1 (contd.): Joist hanger type A with external flanges:
Form factors $k_{H,1}$ and $k_{H,2}$ and dimensions e_1 , e_2 ; $e_{j,0} = 32$ mm

B [mm]	H [mm]	n_H	n_J	$k_{H,1}$	$k_{H,2}$	e_1 [mm]	e_2 [mm]	n_H	n_J	$k_{H,1}$	$k_{H,2}$	e_1 [mm]	e_2 [mm]
		Full nailing						Partial nailing					
60	90	10	6	12,6	2,60	1474	464	6	4	7,74	1,74	648	298
62	89	10	6	12,3	2,64	1526	473	6	4	7,57	1,76	674	303
64	88	10	6	12,1	2,68	1579	482	6	4	7,41	1,79	701	308
66	87	10	6	11,8	2,72	1633	491	6	4	7,25	1,81	729	313
68	86	10	6	11,5	2,76	1688	500	6	4	7,09	1,84	757	319
70	85	10	6	11,2	2,80	1744	509	6	4	6,93	1,87	786	324
72	84	10	6	11,0	2,84	1801	518	6	4	6,77	1,89	815	329
74	83	10	6	10,7	2,88	1859	527	6	4	6,61	1,92	845	335
76	82	10	6	10,4	2,93	1918	537	6	4	6,45	1,95	876	340
78	81	10	6	10,2	2,98	1978	546	6	4	6,30	1,98	907	345
80	80	10	6	9,90	3,02	2039	555	6	4	6,14	2,02	939	351
32	109	14	8	19,8	6,25	909	551	8	4	11,6	3,85	365	372
36	107	14	8	19,1	6,39	982	572	8	4	11,2	3,93	398	379
38	106	14	8	18,7	6,46	1020	583	8	4	11,0	3,98	415	383
40	105	14	8	18,3	6,54	1058	593	8	4	10,8	4,02	433	387
45	102,5	14	8	17,4	6,73	1159	621	8	4	10,3	4,14	479	399
50	100	14	8	16,6	6,94	1266	649	8	4	9,77	4,27	529	412
40	110	14	8	20,2	6,18	1058	593	14	8	20,2	6,18	1058	593
45	107,5	14	8	19,3	6,35	1159	621	14	8	19,3	6,35	1159	621
50	105	14	8	18,3	6,54	1266	649	14	8	18,3	6,54	1266	649
52	104	14	8	18,0	6,61	1311	661	14	8	18,0	6,61	1311	661
54	103	14	8	17,6	6,69	1356	672	14	8	17,6	6,69	1356	672
56	102	14	8	17,3	6,77	1402	684	14	8	17,3	6,77	1402	684
58	101	14	8	16,9	6,85	1450	696	14	8	16,9	6,85	1450	696
60	100	14	8	16,6	6,94	1498	708	14	8	16,6	6,94	1498	708
40	120	14	8	23,5	4,11	946	619	8	4	11,8	3,80	371	387
45	117,5	14	8	22,6	4,21	1033	646	8	4	11,3	3,91	411	399
50	115	14	8	21,6	4,32	1125	673	8	4	10,8	4,02	453	412
52	114	14	8	21,3	4,36	1163	684	8	4	10,6	4,07	471	417
54	113	14	8	20,9	4,41	1202	695	8	4	10,4	4,12	489	423
56	112	14	8	20,5	4,45	1241	706	8	4	10,2	4,17	508	428
58	111	14	8	20,2	4,50	1282	718	8	4	9,97	4,22	527	434
60	110	14	8	19,8	4,55	1323	729	8	4	9,77	4,27	547	440
62	109	14	8	19,5	4,60	1365	741	8	4	9,57	4,32	567	446
64	108	14	8	19,1	4,65	1408	752	8	4	9,38	4,38	587	452
66	107	14	8	18,7	4,71	1452	764	8	4	9,18	4,43	609	458
68	106	14	8	18,4	4,76	1496	776	8	4	8,99	4,49	630	464
70	105	14	8	18,0	4,81	1541	787	8	4	8,80	4,55	652	470
72	104	14	8	17,7	4,87	1587	799	8	4	8,61	4,61	674	477
74	103	14	8	17,3	4,93	1634	811	8	4	8,42	4,67	697	483
76	102	14	8	17,0	4,99	1682	823	8	4	8,23	4,73	721	490
78	101	14	8	16,6	5,05	1730	835	8	4	8,04	4,79	744	496
80	100	14	8	16,3	5,11	1780	847	8	4	7,86	4,86	769	503

Table C1 (contd.): Joist hanger type A with external flanges:
Form factors $k_{H,1}$ and $k_{H,2}$ and dimensions e_1 , e_2 ; $e_{J,0} = 32$ mm

B [mm]	H [mm]	n_H	n_J	$k_{H,1}$	$k_{H,2}$	e_1 [mm]	e_2 [mm]	n_H	n_J	$k_{H,1}$	$k_{H,2}$	e_1 [mm]	e_2 [mm]
		Full nailing						Partial nailing					
45	127,5	14	8	26,9	5,19	1159	621	8	4	15,6	3,20	479	399
50	125	14	8	25,9	5,32	1266	649	8	4	15,0	3,27	529	412
52	124	14	8	25,5	5,37	1311	661	8	4	14,8	3,30	549	417
54	123	14	8	25,1	5,42	1356	672	8	4	14,6	3,33	571	423
56	122	14	8	24,7	5,47	1402	684	8	4	14,4	3,37	593	428
58	121	14	8	24,3	5,52	1450	696	8	4	14,1	3,40	615	434
60	120	14	8	24,0	5,58	1498	708	8	4	13,9	3,43	638	440
62	119	14	8	23,6	5,63	1547	719	8	4	13,7	3,47	661	446
64	118	14	8	23,2	5,69	1597	731	8	4	13,5	3,50	685	452
66	117	14	8	22,8	5,74	1648	743	8	4	13,3	3,54	710	458
68	116	14	8	22,4	5,80	1700	755	8	4	13,1	3,57	735	464
70	115	14	8	22,1	5,86	1752	767	8	4	12,9	3,61	761	470
72	114	14	8	21,7	5,92	1806	780	8	4	12,6	3,65	787	477
74	113	14	8	21,3	5,99	1861	792	8	4	12,4	3,68	813	483
76	112	14	8	20,9	6,05	1916	804	8	4	12,2	3,72	841	490
78	111	14	8	20,6	6,12	1973	816	8	4	12,0	3,76	868	496
80	110	14	8	20,2	6,18	2030	829	8	4	11,8	3,80	897	503
82	109	14	8	19,8	6,25	2089	841	8	4	11,6	3,85	925	509
84	108	14	8	19,4	6,32	2148	854	8	4	11,4	3,89	955	516
86	107	14	8	19,1	6,39	2208	866	8	4	11,2	3,93	985	523
88	106	14	8	18,7	6,46	2270	879	8	4	11,0	3,98	1015	530
90	105	14	8	18,3	6,54	2332	891	8	4	10,8	4,02	1046	536
92	104	14	8	18,0	6,61	2395	904	8	4	10,6	4,07	1077	543
94	103	14	8	17,6	6,69	2459	916	8	4	10,4	4,12	1109	550
96	102	14	8	17,3	6,77	2524	929	8	4	10,2	4,17	1142	557
98	101	14	8	16,9	6,85	2590	942	8	4	9,97	4,22	1175	564
100	100	14	8	16,6	6,94	2656	954	8	4	9,77	4,27	1209	571
50	135	16	10	32,5	7,12	1381	826	8	6	14,9	4,43	492	447
52	134	16	10	32,1	7,18	1426	839	8	6	14,7	4,47	509	451
54	133	16	10	31,6	7,24	1471	851	8	6	14,5	4,51	528	456
56	132	16	10	31,2	7,31	1518	864	8	6	14,3	4,55	547	461
58	131	16	10	30,7	7,37	1566	877	8	6	14,1	4,59	566	466
60	130	16	10	30,3	7,44	1614	890	8	6	13,9	4,63	585	471
62	129	16	10	29,9	7,50	1663	903	8	6	13,7	4,67	605	476
64	128	16	10	29,4	7,57	1714	916	8	6	13,5	4,72	626	482
66	127	16	10	29,0	7,64	1765	929	8	6	13,3	4,76	647	487
68	126	16	10	28,6	7,71	1817	942	8	6	13,1	4,80	669	493
70	125	16	10	28,2	7,78	1870	955	8	6	12,8	4,85	691	498
72	124	16	10	27,7	7,86	1924	969	8	6	12,6	4,89	713	504
74	123	16	10	27,3	7,93	1979	982	8	6	12,4	4,94	736	510
76	122	16	10	26,9	8,01	2035	996	8	6	12,2	4,99	759	516
78	121	16	10	26,5	8,09	2091	1010	8	6	12,0	5,04	783	522
80	120	16	10	26,0	8,16	2149	1023	8	6	11,8	5,09	807	528

Table C1 (contd.): Joist hanger type A with external flanges:
Form factors $k_{H,1}$ and $k_{H,2}$ and dimensions e_1 , e_2 ; $e_{J,0} = 32$ mm

B [mm]	H [mm]	n_H	n_J	$k_{H,1}$	$k_{H,2}$	e_1 [mm]	e_2 [mm]	n_H	n_J	$k_{H,1}$	$k_{H,2}$	e_1 [mm]	e_2 [mm]
		Full nailing						Partial nailing					
82	119	16	10	25,6	8,25	2207	1037	8	6	11,6	5,14	832	534
84	118	16	10	25,2	8,33	2267	1051	8	6	11,4	5,19	857	540
86	117	16	10	24,8	8,41	2327	1065	8	6	11,2	5,24	883	547
88	116	16	10	24,4	8,50	2388	1079	8	6	11,0	5,29	909	553
90	115	16	10	24,0	8,59	2451	1093	8	6	10,8	5,35	935	559
92	114	16	10	23,6	8,68	2514	1107	8	6	10,7	5,40	962	566
94	113	16	10	23,1	8,77	2578	1121	8	6	10,5	5,46	989	572
96	112	16	10	22,7	8,86	2643	1135	8	6	10,3	5,52	1017	579
98	111	16	10	22,3	8,95	2708	1149	8	6	10,1	5,58	1046	586
100	110	16	10	21,9	9,05	2775	1163	8	6	9,89	5,64	1075	592
50	145	18	10	36,8	9,71	1341	917	10	6	20,6	5,91	571	593
52	144	18	10	36,3	9,78	1384	931	10	6	20,3	5,95	590	598
54	143	18	10	35,8	9,86	1428	944	10	6	20,1	6,00	610	603
56	142	18	10	35,3	9,94	1473	958	10	6	19,8	6,05	631	608
58	141	18	10	34,8	10,0	1519	972	10	6	19,5	6,10	652	613
60	140	18	10	34,4	10,1	1566	986	10	6	19,3	6,15	673	619
62	139	18	10	33,9	10,2	1613	1000	10	6	19,0	6,20	695	625
64	138	18	10	33,4	10,3	1662	1015	10	6	18,8	6,25	718	631
66	137	18	10	32,9	10,4	1711	1029	10	6	18,5	6,30	741	637
68	136	18	10	32,4	10,4	1761	1044	10	6	18,2	6,36	764	643
70	135	18	10	32,0	10,5	1813	1058	10	6	18,0	6,41	788	650
72	134	18	10	31,5	10,6	1865	1073	10	6	17,7	6,47	813	657
74	133	18	10	31,0	10,7	1918	1088	10	6	17,5	6,52	838	663
76	132	18	10	30,6	10,8	1972	1103	10	6	17,2	6,58	863	670
78	131	18	10	30,1	10,9	2026	1118	10	6	16,9	6,64	889	677
80	130	18	10	29,6	11,0	2082	1133	10	6	16,7	6,70	916	685
82	129	18	10	29,2	11,1	2139	1148	10	6	16,4	6,76	943	692
84	128	18	10	28,7	11,2	2196	1164	10	6	16,2	6,82	970	699
86	127	18	10	28,2	11,3	2255	1179	10	6	15,9	6,88	998	707
88	126	18	10	27,8	11,4	2314	1194	10	6	15,7	6,94	1027	714
90	125	18	10	27,3	11,5	2374	1210	10	6	15,4	7,01	1056	722
92	124	18	10	26,9	11,6	2435	1225	10	6	15,2	7,08	1085	729
94	123	18	10	26,4	11,7	2497	1241	10	6	15,0	7,14	1115	737
96	122	18	10	26,0	11,9	2560	1257	10	6	14,7	7,21	1146	745
98	121	18	10	25,5	12,0	2624	1272	10	6	14,5	7,28	1177	753
100	120	18	10	25,1	12,1	2689	1288	10	6	14,2	7,35	1208	761
60	150	22	12	40,6	13,9	1573	1363	12	6	19,5	11,3	667	844
62	149	22	12	40,0	14,0	1616	1378	12	6	19,2	11,4	687	849
64	148	22	12	39,5	14,1	1659	1393	12	6	19,0	11,5	706	854
66	147	22	12	39,0	14,2	1703	1409	12	6	18,7	11,6	726	859
68	146	22	12	38,4	14,3	1748	1424	12	6	18,4	11,7	747	865
70	145	22	12	37,9	14,4	1794	1440	12	6	18,1	11,8	768	871
72	144	22	12	37,3	14,6	1840	1456	12	6	17,9	11,9	789	877

Table C1 (contd.): Joist hanger type A with external flanges:
Form factors $k_{H,1}$ and $k_{H,2}$ and dimensions e_1 , e_2 ; $e_{J,0} = 32$ mm

B [mm]	H [mm]	n_H	n_J	$k_{H,1}$	$k_{H,2}$	e_1 [mm]	e_2 [mm]	n_H	n_J	$k_{H,1}$	$k_{H,2}$	e_1 [mm]	e_2 [mm]
		Full nailing						Partial nailing					
74	143	22	12	36,8	14,7	1887	1472	12	6	17,6	12,0	811	883
76	142	22	12	36,3	14,8	1935	1489	12	6	17,3	12,1	833	890
78	141	22	12	35,8	14,9	1984	1505	12	6	17,0	12,2	856	897
80	140	22	12	35,2	15,0	2034	1522	12	6	16,8	12,3	879	904
60	160	24	12	46,6	22,6	1615	1526	14	6	25,6	16,0	815	1124
62	159	24	12	46,0	22,8	1657	1541	14	6	25,3	16,1	835	1126
64	158	24	12	45,4	22,9	1700	1557	14	6	25,0	16,3	856	1129
66	157	24	12	44,8	23,1	1743	1573	14	6	24,7	16,4	878	1133
68	156	24	12	44,3	23,3	1788	1589	14	6	24,4	16,5	900	1137
70	155	24	12	43,7	23,4	1833	1605	14	6	24,0	16,6	922	1141
72	154	24	12	43,1	23,6	1878	1622	14	6	23,7	16,7	945	1146
74	153	24	12	42,5	23,8	1925	1638	14	6	23,4	16,9	968	1151
76	152	24	12	42,0	24,0	1973	1655	14	6	23,1	17,0	992	1156
78	151	24	12	41,4	24,1	2021	1672	14	6	22,8	17,1	1016	1162
80	150	24	12	40,8	24,3	2070	1690	14	6	22,5	17,2	1041	1168
82	149	24	12	40,2	24,5	2120	1707	14	6	22,2	17,4	1066	1174
84	148	24	12	39,7	24,7	2170	1725	14	6	21,9	17,5	1092	1181
86	147	24	12	39,1	24,9	2222	1743	14	6	21,6	17,6	1118	1187
88	146	24	12	38,6	25,1	2274	1761	14	6	21,3	17,8	1145	1195
90	145	24	12	38,0	25,3	2327	1779	14	6	21,0	17,9	1172	1202
92	144	24	12	37,5	25,5	2381	1797	14	6	20,7	18,1	1199	1209
94	143	24	12	36,9	25,7	2436	1815	14	6	20,4	18,2	1227	1217
96	142	24	12	36,4	25,9	2491	1834	14	6	20,1	18,3	1256	1225
98	141	24	12	35,8	26,1	2548	1853	14	6	19,8	18,5	1285	1233
100	140	24	12	35,3	26,3	2605	1872	14	6	19,5	18,6	1314	1242
60	170	22	12	51,9	12,1	1573	1363	12	6	25,4	9,68	667	844
62	169	22	12	51,3	12,1	1616	1378	12	6	25,1	9,75	687	849
64	168	22	12	50,7	12,2	1659	1393	12	6	24,8	9,82	706	854
66	167	22	12	50,2	12,3	1703	1409	12	6	24,5	9,89	726	859
68	166	22	12	49,6	12,4	1748	1424	12	6	24,2	9,96	747	865
70	165	22	12	49,0	12,5	1794	1440	12	6	23,9	10,0	768	871
72	164	22	12	48,4	12,6	1840	1456	12	6	23,6	10,1	789	877
74	163	22	12	47,9	12,7	1887	1472	12	6	23,3	10,2	811	883
76	162	22	12	47,3	12,7	1935	1489	12	6	23,0	10,3	833	890
78	161	22	12	46,7	12,8	1984	1505	12	6	22,7	10,3	856	897
80	160	22	12	46,2	12,9	2034	1522	12	6	22,4	10,4	879	904
82	159	22	12	45,6	13,0	2084	1539	12	6	22,1	10,5	903	911
84	158	22	12	45,0	13,1	2136	1556	12	6	21,8	10,6	927	918
86	157	22	12	44,5	13,2	2188	1573	12	6	21,5	10,7	951	926
88	156	22	12	43,9	13,3	2241	1590	12	6	21,2	10,7	976	933
90	155	22	12	43,3	13,4	2294	1608	12	6	21,0	10,8	1001	941
92	154	22	12	42,8	13,5	2349	1625	12	6	20,7	10,9	1027	949
94	153	22	12	42,2	13,6	2404	1643	12	6	20,4	11,0	1053	957

Table C1 (contd.): Joist hanger type A with external flanges:
Form factors $k_{H,1}$ and $k_{H,2}$ and dimensions e_1 , e_2 ; $e_{1,0} = 32$ mm

B [mm]	H [mm]	n_H	n_J	$k_{H,1}$	$k_{H,2}$	e_1 [mm]	e_2 [mm]	n_H	n_J	$k_{H,1}$	$k_{H,2}$	e_1 [mm]	e_2 [mm]
		Full nailing						Partial nailing					
96	152	22	12	41,7	13,7	2460	1660	12	6	20,1	11,1	1080	966
98	151	22	12	41,1	13,8	2517	1678	12	6	19,8	11,2	1107	974
100	150	22	12	40,6	13,9	2575	1696	12	6	19,5	11,3	1134	982
102	149	22	12	40,0	14,0	2633	1714	12	6	19,2	11,4	1162	991
104	148	22	12	39,5	14,1	2692	1732	12	6	19,0	11,5	1191	1000
106	147	22	12	39,0	14,2	2753	1750	12	6	18,7	11,6	1219	1009
108	146	22	12	38,4	14,3	2813	1768	12	6	18,4	11,7	1249	1017
110	145	22	12	37,9	14,4	2875	1787	12	6	18,1	11,8	1278	1026
112	144	22	12	37,3	14,6	2938	1805	12	6	17,9	11,9	1308	1035
114	143	22	12	36,8	14,7	3001	1824	12	6	17,6	12,0	1339	1045
116	142	22	12	36,3	14,8	3065	1842	12	6	17,3	12,1	1370	1054
118	141	22	12	35,8	14,9	3130	1861	12	6	17,0	12,2	1401	1063
120	140	22	12	35,2	15,0	3195	1880	12	6	16,8	12,3	1433	1072
80	170	26	14	53,5	25,6	2327	1900	14	8	29,0	15,0	1041	1168
82	169	26	14	52,9	25,8	2382	1918	14	8	28,6	15,1	1066	1174
84	168	26	14	52,2	26,0	2437	1937	14	8	28,3	15,2	1092	1181
86	167	26	14	51,6	26,2	2494	1956	14	8	28,0	15,3	1118	1187
88	166	26	14	51,0	26,3	2551	1975	14	8	27,6	15,4	1145	1195
90	165	26	14	50,3	26,5	2610	1995	14	8	27,3	15,5	1172	1202
92	164	26	14	49,7	26,7	2669	2014	14	8	27,0	15,6	1199	1209
94	163	26	14	49,1	26,9	2729	2034	14	8	26,6	15,7	1227	1217
96	162	26	14	48,4	27,1	2790	2054	14	8	26,3	15,8	1256	1225
98	161	26	14	47,8	27,3	2851	2074	14	8	26,0	15,9	1285	1233
100	160	26	14	47,2	27,5	2914	2094	14	8	25,6	16,0	1314	1242
60	190	26	14	66,6	18,5	1736	1777	14	8	32,4	14,0	752	1124
62	189	26	14	65,9	18,6	1778	1792	14	8	32,1	14,1	771	1126
64	188	26	14	65,2	18,7	1822	1808	14	8	31,7	14,2	791	1129
66	187	26	14	64,5	18,9	1866	1824	14	8	31,4	14,3	810	1133
68	186	26	14	63,9	19,0	1911	1840	14	8	31,0	14,4	831	1137
70	185	26	14	63,2	19,1	1957	1857	14	8	30,7	14,5	851	1141
72	184	26	14	62,5	19,2	2003	1874	14	8	30,3	14,6	872	1146
74	183	26	14	61,9	19,3	2051	1891	14	8	30,0	14,7	894	1151
76	182	26	14	61,2	19,4	2099	1908	14	8	29,6	14,8	916	1156
78	181	26	14	60,6	19,5	2148	1926	14	8	29,3	14,9	938	1162
80	180	26	14	59,9	19,7	2198	1943	14	8	29,0	15,0	961	1168
82	179	26	14	59,2	19,8	2248	1962	14	8	28,6	15,1	984	1174
84	178	26	14	58,6	19,9	2300	1980	14	8	28,3	15,2	1008	1181
86	177	26	14	57,9	20,0	2352	1998	14	8	28,0	15,3	1032	1187
88	176	26	14	57,3	20,2	2405	2017	14	8	27,6	15,4	1057	1195
90	175	26	14	56,6	20,3	2459	2036	14	8	27,3	15,5	1082	1202
92	174	26	14	56,0	20,4	2513	2055	14	8	27,0	15,6	1107	1209
94	173	26	14	55,3	20,6	2569	2074	14	8	26,6	15,7	1133	1217
96	172	26	14	54,7	20,7	2625	2093	14	8	26,3	15,8	1159	1225

Table C1 (contd.): Joist hanger type A with external flanges:
Form factors $k_{H,1}$ and $k_{H,2}$ and dimensions e_1 , e_2 ; $e_{1,0} = 32$ mm

B [mm]	H [mm]	n_H	n_J	$k_{H,1}$	$k_{H,2}$	e_1 [mm]	e_2 [mm]	n_H	n_J	$k_{H,1}$	$k_{H,2}$	e_1 [mm]	e_2 [mm]
		Full nailing						Partial nailing					
98	171	26	14	54,1	20,8	2682	2113	14	8	26,0	15,9	1186	1233
100	170	26	14	53,4	21,0	2739	2133	14	8	25,6	16,0	1213	1242
102	169	26	14	52,8	21,1	2798	2152	14	8	25,3	16,1	1241	1250
104	168	26	14	52,2	21,2	2857	2172	14	8	25,0	16,3	1269	1259
106	167	26	14	51,5	21,4	2918	2192	14	8	24,7	16,4	1297	1268
108	166	26	14	50,9	21,5	2979	2213	14	8	24,4	16,5	1326	1277
110	165	26	14	50,3	21,7	3040	2233	14	8	24,0	16,6	1355	1286
112	164	26	14	49,7	21,8	3103	2254	14	8	23,7	16,7	1385	1295
114	163	26	14	49,0	22,0	3166	2274	14	8	23,4	16,9	1415	1305
116	162	26	14	48,4	22,1	3231	2295	14	8	23,1	17,0	1446	1314
118	161	26	14	47,8	22,3	3296	2316	14	8	22,8	17,1	1477	1324
120	160	26	14	47,2	22,4	3361	2337	14	8	22,5	17,2	1508	1334
80	200	30	16	75,4	33,5	2502	2383	16	8	40,2	19,2	1134	1484
82	199	30	16	74,6	33,7	2557	2402	16	8	39,8	19,3	1159	1489
84	198	30	16	73,9	33,9	2612	2422	16	8	39,4	19,4	1184	1493
86	197	30	16	73,1	34,1	2668	2441	16	8	39,1	19,6	1210	1499
88	196	30	16	72,4	34,3	2725	2461	16	8	38,7	19,7	1236	1504
90	195	30	16	71,7	34,5	2782	2481	16	8	38,3	19,8	1262	1510
92	194	30	16	70,9	34,7	2841	2502	16	8	37,9	19,9	1289	1517
94	193	30	16	70,2	34,9	2900	2522	16	8	37,5	20,0	1317	1523
96	192	30	16	69,4	35,1	2961	2543	16	8	37,1	20,1	1345	1530
98	191	30	16	68,7	35,3	3022	2564	16	8	36,7	20,2	1373	1538
100	190	30	16	68,0	35,5	3084	2585	16	8	36,3	20,3	1402	1545
102	189	30	16	67,2	35,7	3147	2607	16	8	36,0	20,5	1431	1553
104	188	30	16	66,5	35,9	3210	2628	16	8	35,6	20,6	1461	1561
106	187	30	16	65,8	36,1	3275	2650	16	8	35,2	20,7	1491	1569
108	186	30	16	65,1	36,3	3340	2672	16	8	34,8	20,8	1521	1578
110	185	30	16	64,3	36,5	3407	2695	16	8	34,5	21,0	1553	1587
112	184	30	16	63,6	36,7	3474	2717	16	8	34,1	21,1	1584	1595
114	183	30	16	62,9	37,0	3542	2740	16	8	33,7	21,2	1616	1605
116	182	30	16	62,2	37,2	3611	2762	16	8	33,3	21,3	1649	1614
118	181	30	16	61,5	37,4	3680	2785	16	8	33,0	21,5	1681	1623
120	180	30	16	60,8	37,7	3751	2808	16	8	32,6	21,6	1715	1633
60	220	30	16	90,8	30,2	2007	2212	16	8	48,3	17,3	913	1468
62	219	30	16	90,0	30,3	2052	2228	16	8	47,9	17,4	933	1467
64	218	30	16	89,3	30,5	2099	2243	16	8	47,5	17,5	953	1466
66	217	30	16	88,5	30,7	2146	2259	16	8	47,1	17,6	974	1467
68	216	30	16	87,7	30,8	2195	2276	16	8	46,7	17,7	996	1467
70	215	30	16	86,9	31,0	2244	2293	16	8	46,3	17,8	1018	1469
72	214	30	16	86,1	31,1	2294	2310	16	8	45,9	17,9	1040	1471
74	213	30	16	85,3	31,3	2345	2328	16	8	45,4	17,9	1063	1473
76	212	30	16	84,6	31,4	2396	2346	16	8	45,0	18,0	1086	1476
78	211	30	16	83,8	31,6	2449	2365	16	8	44,6	18,1	1110	1480

Table C1 (contd.): Joist hanger type A with external flanges:
Form factors $k_{H,1}$ and $k_{H,2}$ and dimensions e_1 , e_2 ; $e_{1,0} = 32$ mm

B [mm]	H [mm]	n_H	n_J	$k_{H,1}$	$k_{H,2}$	e_1 [mm]	e_2 [mm]	n_H	n_J	$k_{H,1}$	$k_{H,2}$	e_1 [mm]	e_2 [mm]
		Full nailing						Partial nailing					
80	210	30	16	83,0	31,8	2502	2383	16	8	44,2	18,2	1134	1484
82	209	30	16	82,2	31,9	2557	2402	16	8	43,8	18,3	1159	1489
84	208	30	16	81,5	32,1	2612	2422	16	8	43,4	18,4	1184	1493
86	207	30	16	80,7	32,3	2668	2441	16	8	43,0	18,5	1210	1499
88	206	30	16	79,9	32,4	2725	2461	16	8	42,6	18,6	1236	1504
90	205	30	16	79,2	32,6	2782	2481	16	8	42,2	18,7	1262	1510
92	204	30	16	78,4	32,8	2841	2502	16	8	41,8	18,8	1289	1517
94	203	30	16	77,7	33,0	2900	2522	16	8	41,4	18,9	1317	1523
96	202	30	16	76,9	33,2	2961	2543	16	8	41,0	19,0	1345	1530
98	201	30	16	76,1	33,3	3022	2564	16	8	40,6	19,1	1373	1538
100	200	30	16	75,4	33,5	3084	2585	16	8	40,2	19,2	1402	1545
102	199	30	16	74,6	33,7	3147	2607	16	8	39,8	19,3	1431	1553
104	198	30	16	73,9	33,9	3210	2628	16	8	39,4	19,4	1461	1561
106	197	30	16	73,1	34,1	3275	2650	16	8	39,1	19,6	1491	1569
108	196	30	16	72,4	34,3	3340	2672	16	8	38,7	19,7	1521	1578
110	195	30	16	71,7	34,5	3407	2695	16	8	38,3	19,8	1553	1587
112	194	30	16	70,9	34,7	3474	2717	16	8	37,9	19,9	1584	1595
114	193	30	16	70,2	34,9	3542	2740	16	8	37,5	20,0	1616	1605
116	192	30	16	69,4	35,1	3611	2762	16	8	37,1	20,1	1649	1614
118	191	30	16	68,7	35,3	3680	2785	16	8	36,7	20,2	1681	1623
120	190	30	16	68,0	35,5	3751	2808	16	8	36,3	20,3	1715	1633
122	189	30	16	67,2	35,7	3822	2831	16	8	36,0	20,5	1749	1643
124	188	30	16	66,5	35,9	3895	2855	16	8	35,6	20,6	1783	1653
126	187	30	16	65,8	36,1	3968	2878	16	8	35,2	20,7	1818	1663
128	186	30	16	65,1	36,3	4042	2902	16	8	34,8	20,8	1853	1674
130	185	30	16	64,3	36,5	4117	2926	16	8	34,5	21,0	1889	1684
132	184	30	16	63,6	36,7	4192	2949	16	8	34,1	21,1	1925	1695
134	183	30	16	62,9	37,0	4269	2973	16	8	33,7	21,2	1961	1705
136	182	30	16	62,2	37,2	4346	2998	16	8	33,3	21,3	1998	1716
138	181	30	16	61,5	37,4	4425	3022	16	8	33,0	21,5	2036	1727
140	180	30	16	60,8	37,7	4504	3046	16	8	32,6	21,6	2074	1738

Table C2:

Joist hanger type I with interior flanges:

Form factors $k_{H,1}$ and $k_{H,2}$ and dimensions e_1 , e_2 ; $e_{1,0} = 32$ mm

B [mm]	H [mm]	n_H	n_J	k_{H,1}	k_{H,2}	e₁ [mm]	e₂ [mm]	n_H	n_J	k_{H,1}	k_{H,2}	e₁ [mm]	e₂ [mm]
		Full nailing						Partial nailing					
46	102	8	8	10,2	4,17	169	440	8	4	10,2	4,17	169	440
48	101	8	8	10,0	4,22	175	420	8	4	10,0	4,22	175	420
50	100	8	8	9,77	4,27	182	404	8	4	9,77	4,27	182	404
46	107	8	8	11,2	3,93	186	398	8	4	11,2	3,93	186	398
48	106	8	8	11,0	3,98	193	387	8	4	11,0	3,98	193	387
50	105	8	8	10,8	4,02	202	378	8	4	10,8	4,02	202	378
52	104	8	8	10,6	4,07	210	371	8	4	10,6	4,07	210	371
54	103	8	8	10,4	4,12	220	366	8	4	10,4	4,12	220	366
56	102	8	8	10,2	4,17	230	363	8	4	10,2	4,17	230	363
58	101	8	8	10,0	4,22	240	360	8	4	10,0	4,22	240	360
60	100	8	8	9,77	4,27	251	358	8	4	9,77	4,27	251	358
80	100	16	8	19,5	8,54	431	529	8	4	9,77	4,27	300	368
80	110	14	8	20,2	6,18	418	440	8	4	11,8	3,80	350	368
82	109	14	8	19,8	6,25	437	444	8	4	11,6	3,85	365	372
84	108	14	8	19,4	6,32	457	449	8	4	11,4	3,89	381	375
86	107	14	8	19,1	6,39	478	455	8	4	11,2	3,93	398	379
88	106	14	8	18,7	6,46	500	461	8	4	11,0	3,98	415	383
90	105	14	8	18,3	6,54	522	468	8	4	10,8	4,02	433	387
92	104	14	8	18,0	6,61	546	475	8	4	10,6	4,07	451	392
94	103	14	8	17,6	6,69	571	482	8	4	10,4	4,12	469	397
96	102	14	8	17,3	6,77	596	490	8	4	10,2	4,17	489	402
98	101	14	8	16,9	6,85	623	498	8	4	10,0	4,22	508	407
100	100	14	8	16,6	6,94	650	507	8	4	9,77	4,27	529	412
60	130	10	10	14,2	9,15	293	713	10	6	14,2	9,15	293	713
62	129	10	10	13,9	9,23	301	696	10	6	13,9	9,23	301	696
64	128	10	10	13,7	9,32	310	681	10	6	13,7	9,32	310	681
66	127	10	10	13,5	9,40	320	669	10	6	13,5	9,40	320	669
68	126	10	10	13,2	9,49	329	659	10	6	13,2	9,49	329	659
70	125	10	10	13,0	9,58	340	650	10	6	13,0	9,58	340	650
72	124	10	10	12,8	9,67	350	643	10	6	12,8	9,67	350	643
74	123	10	10	12,6	9,76	361	638	10	6	12,6	9,76	361	638
76	122	10	10	12,4	9,86	373	633	10	6	12,4	9,86	373	633
78	121	10	10	12,1	9,95	385	630	10	6	12,1	9,95	385	630
80	120	18	10	25,9	13,5	531	839	10	6	11,9	10,0	397	627
82	119	18	10	25,4	13,6	547	835	10	6	11,7	10,1	410	626
84	118	18	10	25,0	13,8	564	832	10	6	11,5	10,3	424	625
86	117	18	10	24,6	13,9	582	831	10	6	11,3	10,4	437	625
88	116	18	10	24,2	14,0	600	831	10	6	11,1	10,5	452	625
90	115	18	10	23,7	14,2	620	832	10	6	10,9	10,6	466	626
60	160	14	12	25,9	15,1	421	1366	14	6	25,9	15,1	421	1366
62	159	14	12	25,6	15,2	430	1323	14	6	25,6	15,2	430	1323
64	158	14	12	25,3	15,3	439	1286	14	6	25,3	15,3	439	1286
66	157	14	12	25,0	15,4	449	1253	14	6	25,0	15,4	449	1253

Table C2 (contd.): Joist hanger type I with interior flanges:
Form factors $k_{H,1}$ and $k_{H,2}$ and dimensions e_1 , e_2 ; $e_{1,0} = 32$ mm

B [mm]	H [mm]	n_H	n_J	$k_{H,1}$	$k_{H,2}$	e_1 [mm]	e_2 [mm]	n_H	n_J	$k_{H,1}$	$k_{H,2}$	e_1 [mm]	e_2 [mm]
		Full nailing						Partial nailing					
68	156	14	12	24,6	15,5	459	1225	14	6	24,6	15,5	459	1225
70	155	14	12	24,3	15,6	470	1200	14	6	24,3	15,6	470	1200
72	154	14	12	24,0	15,7	481	1179	14	6	24,0	15,7	481	1179
74	153	14	12	23,7	15,9	493	1160	14	6	23,7	15,9	493	1160
76	152	14	12	23,3	16,0	505	1144	14	6	23,3	16,0	505	1144
78	151	14	12	23,0	16,1	518	1129	14	6	20,0	17,4	518	1129
80	150	22	12	40,2	18,2	649	1139	12	6	22,4	10,4	475	833
82	149	22	12	39,7	18,4	667	1130	12	6	22,1	10,5	489	829
84	148	22	12	39,1	18,5	685	1123	12	6	21,8	10,6	503	825
86	147	22	12	38,6	18,7	705	1118	12	6	21,5	10,7	518	822
88	146	22	12	38,0	18,8	725	1115	12	6	21,2	10,7	534	821
90	145	22	12	37,5	18,9	746	1113	12	6	21,0	10,8	549	820
92	144	22	12	37,0	19,1	768	1113	12	6	20,7	10,9	566	820
94	143	22	12	36,4	19,3	791	1113	12	6	20,4	11,0	582	820
96	142	22	12	35,9	19,4	814	1115	12	6	20,1	11,1	600	822
98	141	22	12	35,4	19,6	839	1118	12	6	19,8	11,2	618	823
100	140	22	12	34,8	19,7	864	1122	12	6	19,5	11,3	636	826
60	190	14	16	31,7	16,5	458	1609	14	8	31,7	16,5	458	1609
62	189	14	16	31,4	16,6	466	1554	14	8	31,4	16,6	466	1554
64	188	14	16	31,1	16,7	475	1505	14	8	31,1	16,7	475	1505
66	187	14	16	30,7	16,8	484	1462	14	8	30,7	16,8	484	1462
68	186	14	16	30,4	16,9	493	1425	14	8	30,4	16,9	493	1425
70	185	14	16	30,1	17,0	503	1392	14	8	30,1	17,0	503	1392
72	184	14	16	29,7	17,1	513	1362	14	8	29,7	17,1	513	1362
74	183	14	16	29,4	17,2	524	1336	14	8	29,4	17,2	524	1336
76	182	14	16	29,1	17,3	535	1313	14	8	29,1	17,3	535	1313
78	181	14	16	28,7	17,4	547	1293	14	8	28,7	17,4	547	1293
80	180	26	16	60,1	26,0	1290	1729	14	8	28,4	17,5	891	1194
82	179	26	16	59,5	26,2	1322	1736	14	8	28,1	17,6	912	1197
84	178	26	16	58,8	26,3	1355	1744	14	8	27,7	17,7	933	1201
86	177	26	16	58,2	26,5	1388	1752	14	8	27,4	17,8	955	1206
88	176	26	16	57,5	26,7	1423	1761	14	8	27,1	18,0	978	1211
90	175	26	16	56,9	26,8	1458	1771	14	8	26,8	18,1	1001	1216
92	174	26	16	56,3	27,0	1493	1781	14	8	26,4	18,2	1024	1221
94	173	26	16	55,6	27,2	1530	1792	14	8	26,1	18,3	1048	1227
96	172	26	16	55,0	27,4	1567	1803	14	8	25,8	18,4	1072	1233
98	171	26	16	54,3	27,5	1606	1815	14	8	25,5	18,5	1096	1239
100	170	26	16	53,7	27,7	1645	1827	14	8	25,2	18,7	1121	1246
102	169	26	16	53,1	27,9	1684	1840	14	8	24,9	18,8	1147	1253
104	168	26	16	52,5	28,1	1725	1853	14	8	24,5	18,9	1173	1260
106	167	26	16	51,8	28,3	1766	1867	14	8	24,2	19,0	1199	1267
108	166	26	16	51,2	28,5	1809	1881	14	8	23,9	19,2	1226	1275
110	165	26	16	50,6	28,7	1852	1895	14	8	23,6	19,3	1253	1282

Table C2 (contd.): Joist hanger type I with interior flanges:
Form factors $k_{H,1}$ and $k_{H,2}$ and dimensions e_1 , e_2 ; $e_{J,0} = 32$ mm

B [mm]	H [mm]	n_H	n_J	$k_{H,1}$	$k_{H,2}$	e_1 [mm]	e_2 [mm]	n_H	n_J	$k_{H,1}$	$k_{H,2}$	e_1 [mm]	e_2 [mm]
		Full nailing						Partial nailing					
112	164	26	16	50,0	28,9	1895	1910	14	8	23,3	19,4	1280	1290
114	163	26	16	49,4	29,1	1940	1925	14	8	23,0	19,6	1308	1298
116	162	26	16	48,8	29,3	1986	1941	14	8	22,7	19,7	1337	1307
118	161	26	16	48,1	29,5	2032	1956	14	8	22,4	19,8	1366	1315
120	160	26	16	47,5	29,7	2079	1973	14	8	22,1	20,0	1395	1324
60	210	16	18	39,4	22,1	601	2273	16	10	39,4	22,1	601	2273
62	209	16	18	39,0	22,2	609	2188	16	10	39,0	22,2	609	2188
64	208	16	18	38,6	22,3	619	2112	16	10	38,6	22,3	619	2112
66	207	16	18	38,2	22,5	628	2045	16	10	38,2	22,5	628	2045
68	206	16	18	37,8	22,6	638	1986	16	10	37,8	22,6	638	1986
70	205	16	18	37,4	22,7	649	1932	16	10	37,4	22,7	649	1932
72	204	16	18	37,1	22,8	660	1885	16	10	37,1	22,8	660	1885
74	203	16	18	36,7	22,9	671	1842	16	10	36,7	22,9	671	1842
76	202	16	18	36,3	23,1	683	1804	16	10	36,3	23,1	683	1804
78	201	16	18	35,9	23,2	695	1770	16	10	35,9	23,2	695	1770
80	200	30	18	74,2	34,9	1000	2456	16	10	40,2	19,2	666	1635
82	199	30	18	73,5	35,0	1017	2413	16	10	39,8	19,3	679	1611
84	198	30	18	72,7	35,2	1035	2375	16	10	39,4	19,4	693	1590
86	197	30	18	72,0	35,4	1053	2341	16	10	39,1	19,6	707	1571
88	196	30	18	71,3	35,6	1073	2310	16	10	38,7	19,7	721	1554
90	195	30	18	70,5	35,8	1093	2284	16	10	38,3	19,8	737	1539
92	194	30	18	69,8	36,0	1114	2261	16	10	37,9	19,9	752	1526
94	193	30	18	69,1	36,3	1136	2240	16	10	37,5	20,0	768	1514
96	192	30	18	68,3	36,5	1159	2223	16	10	37,1	20,1	785	1505
98	191	30	18	67,6	36,7	1183	2208	16	10	36,7	20,2	801	1496
100	190	30	18	66,9	36,9	1207	2195	16	10	36,3	20,3	819	1489
102	189	30	18	66,2	37,1	1233	2184	16	10	36,0	20,5	837	1483
104	188	30	18	65,4	37,3	1259	2176	16	10	35,6	20,6	855	1478
106	187	30	18	64,7	37,5	1286	2169	16	10	35,2	20,7	874	1474
108	186	30	18	64,0	37,8	1314	2164	16	10	34,8	20,8	893	1471
110	185	30	18	63,3	38,0	1343	2161	16	10	34,5	21,0	913	1468
112	184	30	18	62,6	38,2	1373	2159	16	10	34,1	21,1	933	1467
114	183	30	18	61,9	38,4	1403	2159	16	10	33,7	21,2	953	1466
116	182	30	18	61,2	38,7	1435	2160	16	10	33,3	21,3	974	1467
118	181	30	18	60,5	38,9	1467	2162	16	10	33,0	21,5	996	1467
120	180	30	18	59,8	39,2	1500	2165	16	10	32,6	21,6	1018	1469
60	220	16	18	48,3	17,3	558	2112	16	10	48,3	17,3	558	2112
62	219	16	18	47,9	17,4	567	2035	16	10	47,9	17,4	567	2035
64	218	16	18	47,5	17,5	576	1967	16	10	47,5	17,5	576	1967
66	217	16	18	47,1	17,6	586	1907	16	10	47,1	17,6	586	1907
68	216	16	18	46,7	17,7	596	1853	16	10	46,7	17,7	596	1853
70	215	16	18	46,3	17,8	606	1806	16	10	46,3	17,8	606	1806
72	214	16	18	45,9	17,9	617	1763	16	10	45,9	17,9	617	1763

Table C2 (contd.): Joist hanger type I with interior flanges:
Form factors $k_{H,1}$ and $k_{H,2}$ and dimensions e_1 , e_2 ; $e_{j,0} = 32$ mm

B [mm]	H [mm]	n_H	n_J	$k_{H,1}$	$k_{H,2}$	e_1 [mm]	e_2 [mm]	n_H	n_J	$k_{H,1}$	$k_{H,2}$	e_1 [mm]	e_2 [mm]
		Full nailing						Partial nailing					
74	213	16	18	45,4	17,9	629	1726	16	10	45,4	17,9	629	1726
76	212	16	18	45,0	18,0	641	1692	16	10	45,0	18,0	641	1692
78	211	16	18	44,6	18,1	609	1662	16	10	44,6	18,1	609	1662
80	210	30	18	81,8	33,0	1000	2456	16	10	44,2	18,2	666	1635
82	209	30	18	81,0	33,2	1017	2413	16	10	43,8	18,3	679	1611
84	208	30	18	80,3	33,4	1035	2375	16	10	43,4	18,4	693	1590
86	207	30	18	79,5	33,6	1053	2341	16	10	43,0	18,5	707	1571
88	206	30	18	78,7	33,7	1073	2310	16	10	42,6	18,6	721	1554
90	205	30	18	78,0	33,9	1093	2284	16	10	42,2	18,7	737	1539
92	204	30	18	77,2	34,1	1114	2261	16	10	41,8	18,8	752	1526
94	203	30	18	76,5	34,3	1136	2240	16	10	41,4	18,9	768	1514
96	202	30	18	75,7	34,5	1159	2223	16	10	41,0	19,0	785	1505
98	201	30	18	75,0	34,7	1183	2208	16	10	40,6	19,1	801	1496
100	200	30	18	74,2	34,9	1207	2195	16	10	40,2	19,2	819	1489
102	199	30	18	73,5	35,0	1233	2184	16	10	39,8	19,3	837	1483
104	198	30	18	72,7	35,2	1259	2176	16	10	39,4	19,4	855	1478
106	197	30	18	72,0	35,4	1286	2169	16	10	39,1	19,6	874	1474
108	196	30	18	71,3	35,6	1314	2164	16	10	38,7	19,7	893	1471
110	195	30	18	70,5	35,8	1343	2161	16	10	38,3	19,8	913	1468
112	194	30	18	69,8	36,0	1373	2159	16	10	37,9	19,9	933	1467
114	193	30	18	69,1	36,3	1403	2159	16	10	37,5	20,0	953	1466
116	192	30	18	68,3	36,5	1435	2160	16	10	37,1	20,1	974	1467
118	191	30	18	67,6	36,7	1467	2162	16	10	36,7	20,2	996	1467
120	190	30	18	66,9	36,9	1500	2165	16	10	36,3	20,3	1018	1469
122	189	30	18	66,2	37,1	1534	2169	16	10	36,0	20,5	1040	1471
124	188	30	18	65,4	37,3	1569	2175	16	10	35,6	20,6	1063	1473
126	187	30	18	64,7	37,5	1605	2181	16	10	35,2	20,7	1086	1476
128	186	30	18	64,0	37,8	1641	2188	16	10	34,8	20,8	1110	1480
130	185	30	18	63,3	38,0	1679	2196	16	10	34,5	21,0	1134	1484
132	184	30	18	62,6	38,2	1717	2205	16	10	34,1	21,1	1159	1489
134	183	30	18	61,9	38,4	1756	2215	16	10	33,7	21,2	1184	1493
136	182	30	18	61,2	38,7	1796	2225	16	10	33,3	21,3	1210	1499
138	181	30	18	60,5	38,9	1837	2236	16	10	33,0	21,5	1236	1504
140	180	30	18	59,8	39,2	1879	2248	16	10	32,6	21,6	1262	1510

Annex D Application of joist hangers

Joist hanger in wood/wood connection

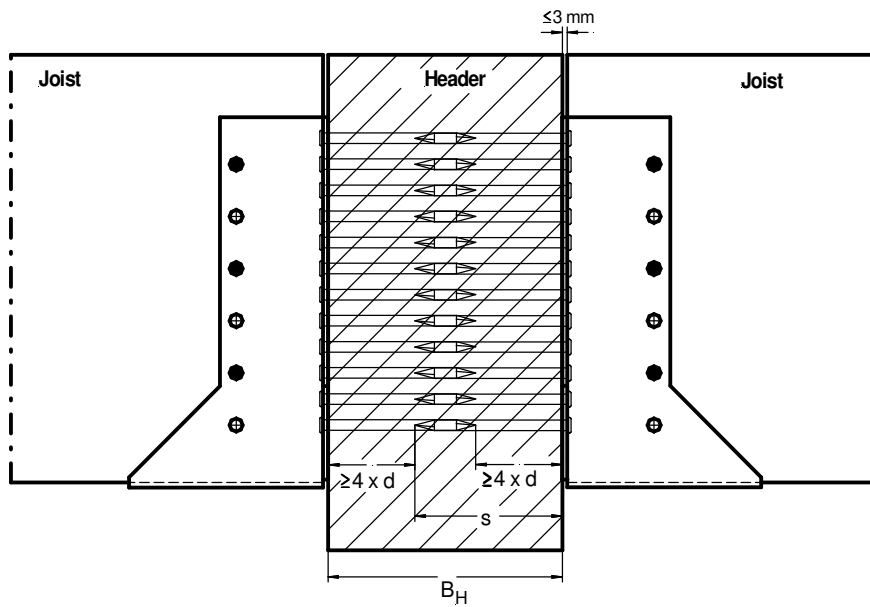
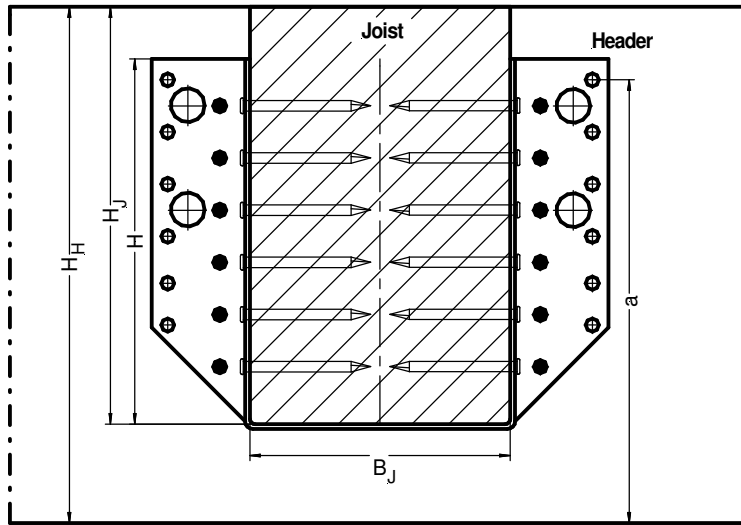

**Joist hanger connected to concrete, lightweight concrete
or a steel member by bolts**

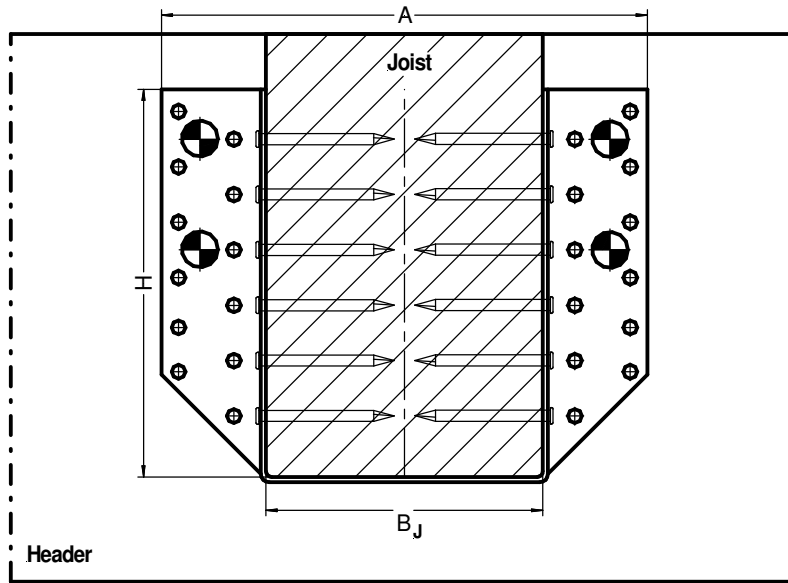

Bolts M10
Washer according to
EN ISO 7094

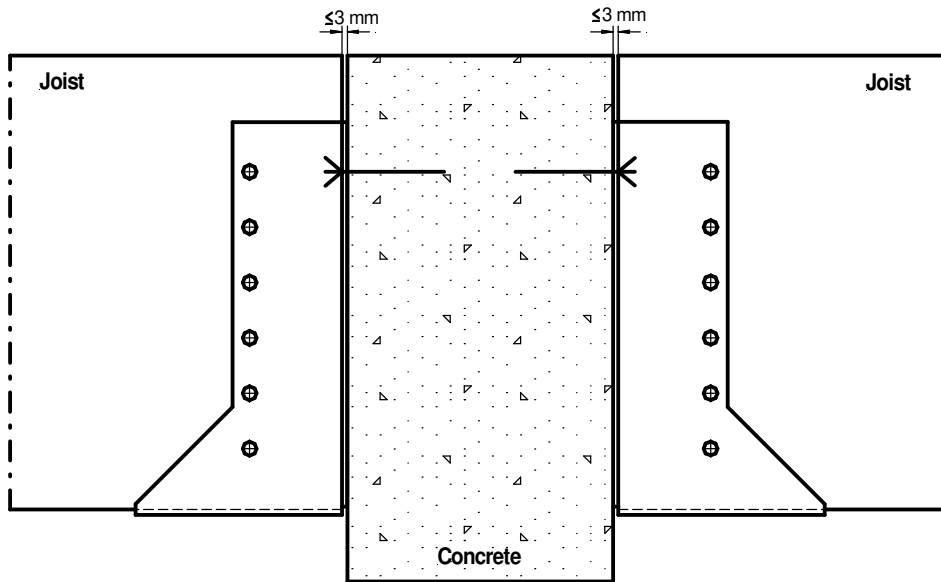



Universität Karlsruhe (TH)
Forschungsuniversität • gegründet 1825

Versuchsanstalt für
Stahl, Holz und Steine
Amtliche Materialprüfungsanstalt



Zertifikat über die werkseigene Produktionskontrolle 0769-CPD-6018

Gemäß der Richtlinie 89/106/EWG des Rates der Europäischen Gemeinschaften vom 21. Dezember 1988 zur Angleichung der Rechts- und Verwaltungsvorschriften der Mitgliedstaaten über Bauprodukte (Bauproduktenrichtlinie - CPD), geändert durch die Richtlinie 93/68/EWG des Rates der Europäischen Gemeinschaften vom 22. Juli 1993, umgesetzt in Deutschland durch das Bauproduktengesetz (BauPG) vom 28. April 1998, wird hiermit bestätigt, dass das Bauprodukt

BB Joist Hangers type A, I and Split 2 mm

**Three-dimensional nailing plate (Joist hanger for wood to wood connections
and wood to concrete or steel connections)**

erzeugt vom Hersteller

BB Stanz- und Umformtechnik
Nordhäuser Str. 42
D-06536 Berga

im Herstellwerk

D-06536 Berga

durch den Hersteller einer Erstprüfung der Produkte und einer werkseigenen Produktionskontrolle unterzogen werden und dass die notifizierte Stelle - Versuchsanstalt für Stahl, Holz und Steine - eine Erstinspektion des Werkes und der werkseigenen Produktionskontrolle durchgeführt hat und eine laufende Überwachung, Beurteilung und Anerkennung der werkseigenen Produktionskontrolle durchführt.

Dieses Zertifikat bestätigt, dass alle Vorschriften über die Bescheinigung der werkseigenen Produktionskontrolle, beschrieben in der

ETA-09/0021

angewendet werden.

Dieses Zertifikat wurde erstmals am 27.01.2009 ausgestellt und gilt solange, wie die Festlegungen in der angeführten ETA oder die Herstellbedingungen im Werk oder die werkseigene Produktionskontrolle selbst nicht wesentlich verändert werden.

Karlsruhe, den 27. Januar 2009



Leiter der Zertifizierungsstelle

Univ.-Prof. Dr.-Ing. H. J. Blaß