

Type: EGH**EKEGH150W5K16-T3-D**

Power	150W
Lumen	24.000lm
Dimming Process	DALI
Beam Angle	110°
Color Temperature	5.000K
SDCM	≤ 6
CRI	>80
Voltage	240V AC
IP Class	IP65
Lifetime	50.000h (L80-B10)
Warranty	5 years
Temperature	-35°C ... +55°C
Impact Resistance	IK07
Dimming	DALI
Weight	2,3kg
Switch Cycles	>50.000
Switch on delay	60% in <1 second





Abb. 1: EGH Gehäuse

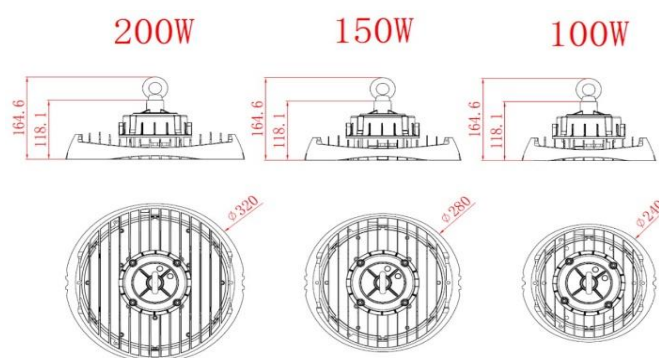

Abb. 2: Seitenan- und Draufsicht der EGH mit Maßen in mm.



Abb. 3: Explosionszeichnung